



Modern HMI/SCADA Guidebook for Efficient Operations

- High Performance HMI
- Rapid Application Development
- Improved Security Practices
- Mobility
- Centralized and Remote Operations
- Industrial Data Management for IoT

Explore Tips & Best Practices





Introduction

Enter the world of today's industrial plant:

- **Aging infrastructure**
- **Increasing revenue challenges**
- **Retiring experienced workers**
- **Increasing service level expectations**
- **Regulations**

What's more, resources for capital programs are usually limited, making it difficult to carry out infrastructure modernization, expansion, and technology upgrades.

How can you address these critical challenges while delivering the best return on investment to investors, private or public? Chances are, your budgets will remain tight with expectations continuing to increase.

So you're left to become as efficient as possible with the assets and people that you have. This means you've got to look at your operations holistically to understand and predict what's happening to make the best decisions for modernizing and optimizing.

Greater Efficiency with the Modern HMI/SCADA

The good news is the technology and solutions are here. They revolutionize what's possible for industrial organizations.

By modernizing your existing HMI/SCADA system, you can have High Performance visualization, real-time information when and where you need it, and the ability to connect the dots between your data, leveraging the Internet of Things (IoT).

The modern HMI/SCADA lets you guide newer operators through the right steps to take. And, you can enable mobility and remote monitoring for greater efficiency.

Welcome to the modern HMI/SCADA system—where machines, data, insights, and people are connected.



Today's Challenges

In general, challenges at an industrial plant are related to three main areas:

- **Availability and reliability:** Examples include aging infrastructure, stability of the system, and reliability of the data coming in.
- **Risk:** Examples include compliance concerns, cybersecurity and physical security, reporting, and errors due to high workforce turnover and experienced operators retiring.
- **Cost:** Examples include raw materials, training newer operators, energy costs, maintenance.

Operations professionals are constantly facing the challenge of finding the right balance between availability and reliability, risk, and cost.

How to reduce cost without compromising availability? How to mitigate risks while keeping costs under control?

Value of Modern HMI/SCADA

The modern HMI/SCADA helps to reduce operating cost, maintain a high level of service, ease compliance with evolving regulatory standards, and increase the efficiency of operators.

Additionally, industrial organizations can use this control layer as a foundation for digital transformation to be better prepared for the future.

By modernizing HMI/SCADA, you can directly address challenges in the three key areas in several ways:



High availability and reliability

- Secure-by-design SCADA
- Disaster recovery architecture
- Information anytime, anywhere

Risk Management

- Reliable data management
- Effective alarm management
- Consistent operating processes
- Improved communication and collaboration across teams

Cost Management

- More efficient operators
- Enhanced operations visibility
- Effective data analysis



Technology suppliers in the automation ecosystem have the challenge and opportunity to help industrial companies cope with these changes while achieving their desired outcomes.

HMI/SCADA Supports Digital Transformation

In today's rapidly changing industrial landscape, manufacturers and utilities must embrace modern HMI/SCADA and digital transformation to keep up with the pace of change, meet growing operations challenges, and remain competitive. The foundation starts with capturing industrial data, combining it with other meaningful data sources for context and managing a historic record. It is data, turned into information, that provides the basis for meaningful outcomes.

Modern HMI/SCADA, including data historian and centralized visualization technologies, empower users to unlock the value of their data. The outcome is a high-productivity development and visualization environment that enables optimized plant operations, supported by faster development, a democratization of tools and capabilities throughout a plant, improved operational performance, lower costs, a changed mindset among employees, and a culture of continuous improvement. Examples of market leaders from multiple sectors illustrate the outcomes companies are achieving.



The Industrial Landscape is Rapidly Changing

Technological innovations are reshaping the industrial landscape. These innovations include cheap sensors, a high-speed telecom infrastructure that can move huge amounts of data, unprecedented computation power, mobile and touch interfaces, and a standards-based open ecosystem for interoperability. This ecosystem includes web-based technologies, APIs for connectivity, machine learning, and AI.

As these technologies evolve and take hold, organizations desire outcomes that include increased revenue and productivity, lower costs, and more consistent quality. Industrial organizations are also dealing with high rates of retirement of aging workers who have deep knowledge and expertise. These individuals are being replaced by younger workers who lack the same knowledge but are digital natives with skills and experience with mobile devices and web-based technologies.

Getting Started: 10 Tips for Modernizing Your HMI/SCADA

Designing and structuring for better operational performance

1. Get up to date with SCADA and OS versions and patches

Many organizations are still on old – sometimes very old – versions of their SCADA software. However, regular updates and alignment to the latest features improve system availability. A lapse in updates increases security concerns. Additionally, you probably have higher, hidden costs by continuing to use an obsolete system.

This is a foundational step. Before you take any other steps to modernize including analytics or web-based interfaces, make sure your SCADA and OS are up to date with versions and patches. This will enable you to start with the right platform to enhance your capabilities.

2. Standardize your SCADA implementation

Improve efficiency by defining standards for the overall SCADA system including application, configuration, security, architecture, and remote access – even the devices that people use.

Standardization will help you reduce errors, lower costs, and boost operations efficiency.

For example, consistent representation and procedures reduce errors across multiple stakeholders. Teams benefit from a shorter learning curve, faster roll-outs, and easier maintenance. Standardization also helps ensure compliance. Lastly, with tag name conventions, you can leverage OPC UA: browse OPC UA sources and automatically create your SCADA process database.

3. Develop a disaster recovery plan

A Disaster Recovery Plan can start simple, such as a versioning plan related to backup and restore. Next, lay out a long-term roadmap and think about moving to a redundant and failover system with configurations for minimal disruption.

You can build redundancy at all levels: SCADA server failover, LAN redundancy, client redundancy. Target having no data lost, looking at your databases, real-time data, and alarm synchronization. Make the system seamless for remote users.

A Disaster Recovery Plan is more than peace of mind; it is an essential part of improving availability and reliability.

4. Implement best-in-class data management

Put together a plan to collect, store and distribute your data securely. You can't operate a plant effectively unless you have all the correct data in a timely fashion.

Consider a plant-wide historian for more reliable and consistent information – collecting from different data sources, providing the ability to extend and scale as your systems grow, and integrating your data management layer with your CMMS. Modern technologies make information available to stakeholders who aren't directly connected with the SCADA but need data to make decisions, such as demand and planning.

5. Build effective alarm procedures

Many resources for effective alarm management are available, such as through ISA. A good alarm strategy means less noise, faster reactions, increased productivity and efficiency, and safer operations. You can move from an alarm to notification and guiding the right action.



6. Digitize work processes

Every facility has standard operating procedures in some form, mostly printed manuals. Now, you can move from manuals to integrating work processes into your SCADA system.

Using SCADA data, you can trigger a work process, guide operators through steps, and increase operational consistency. Electronic Standard Operating Procedures also capture best practices and accelerate new operator training.

Digitize your procedures to ensure:

- Consistency
- Repeatability
- Adherence to standards
- Accountability on tasks

You can drive the right actions and help prevent mistakes from happening. Additionally, you can record and track work processes for compliance.

7. Drive organization-wide connectivity

Organization-wide SCADA connectivity – across the entire enterprise – provides a holistic view of performance, fills data gaps, and increases collaboration. Centralized Information Management drives consistency across plants and sites. You can leverage highly secure-by-design thin clients on inexpensive hardware to make information readily available to all levels of the organization.

8. Leverage persona-based visualization

Give each person the information and capabilities that they need, rather than the same SCADA screen for every person.

Modern HMI/SCADA allows you to equip your workforce with tailored information, remote monitoring and control capabilities, and devices – whether a smartphone, iPad, or legacy device that supports HTML5.

You'll get the right operational information to the people who need it, saving tremendous staff time while speeding response and compliance.

9. Enable model-based HMI navigation

With modern HMI/SCADA, you can leverage industry standards to map your data model to an equipment model – structuring your data and providing standard context across locations and data sources.

Users can quickly navigate in context, derived from the model. Model-based HMI navigation enables a common User Experience regardless of the screen, device, equipment, role, or process.

10. Implement High Performance HMI

High Performance HMI, based on the ISA 101 standards, increases operator efficiency through better screens.

With a simple and consistent design, High Performance screens boost situational awareness, alarm detection, and productivity, while decreasing the risk of errors. Operators and technicians recognize and understand information with greater ease and speed.



Modernizing HMI/SCADA with GE Digital

Have you seen our software lately?

Free Trial Offer



Architectural Examples

Common Deployment Scenario

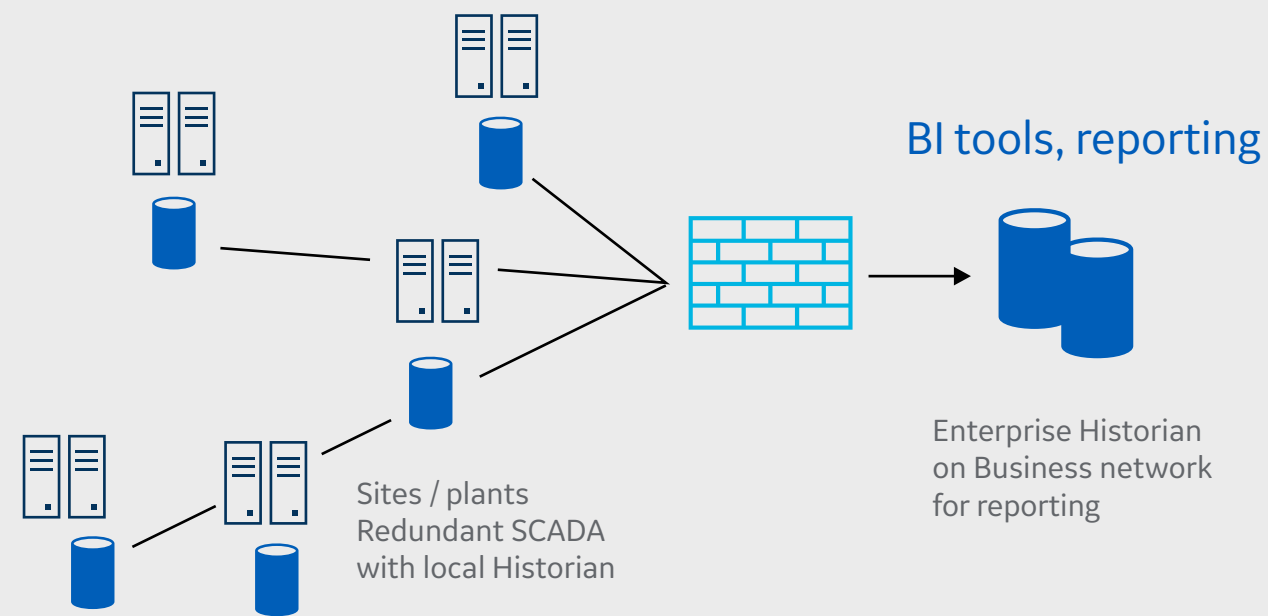

High Availability iFIX with SCADA Synchronization

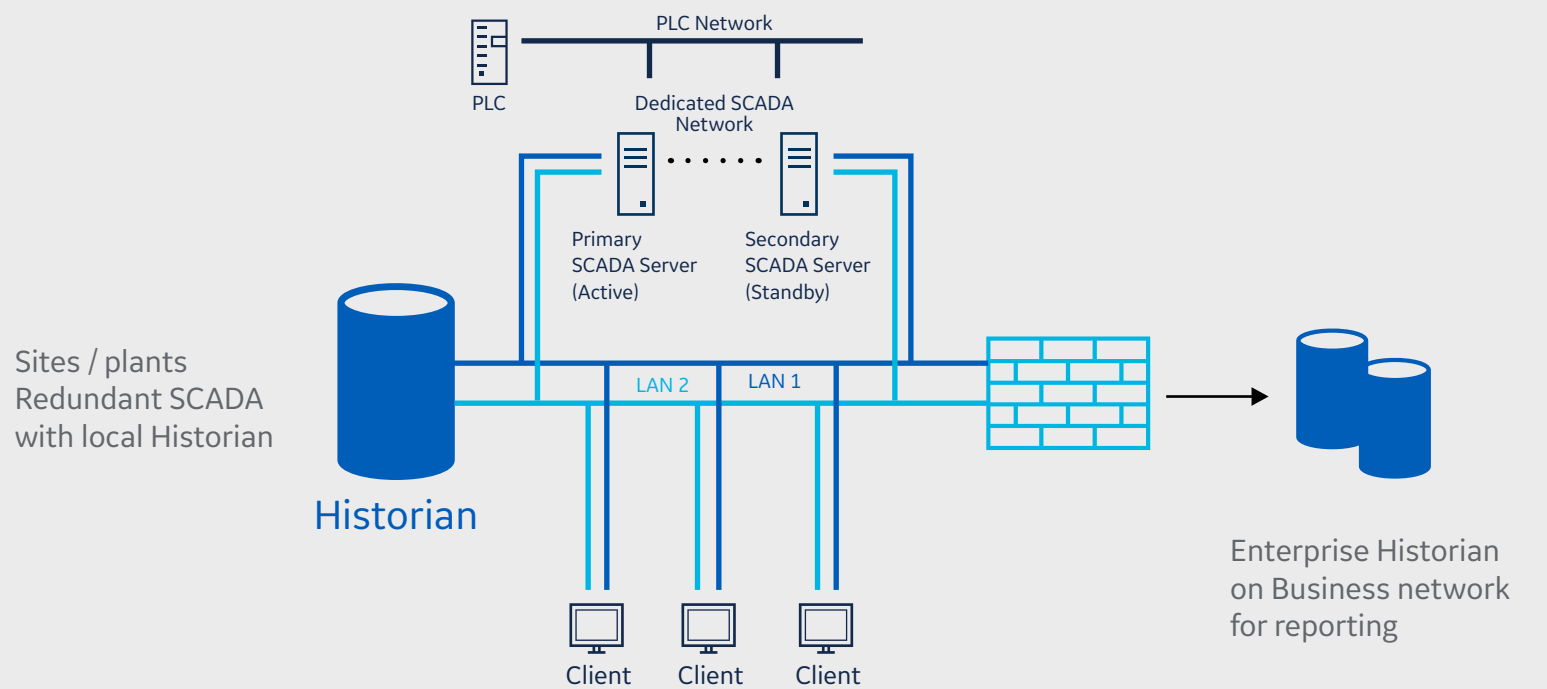

High Performance HMI/SCADA: Busting Myths

The human brain is remarkable. When we process visual information, our mind arranges what we are seeing for understanding, rather than offer a simple reflection of what is shown. However, our ability to do this breaks down when presented with imagery that is overly complex, uses too many different colors and provides no focal point or logical flow.

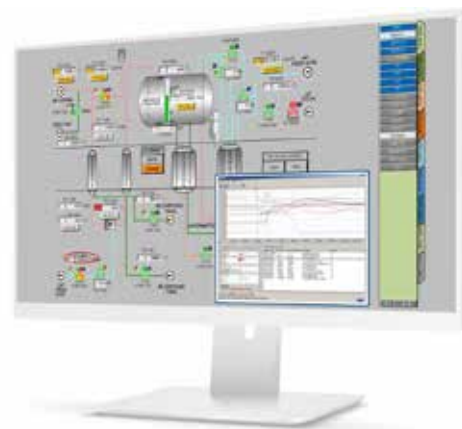

Visually, it's like the odds and ends drawer in your kitchen where you can never find anything quickly. It's distracting, and abnormal conditions don't stand out. Visual presentations like this require advanced training, and slow down an operator's ability to respond to emerging problems.

We can do so much better. With a glance, operators should be able to recognize which information needs their immediate attention. High Performance HMI is the key to optimizing visual information delivery, but it is often misunderstood. Let's breakdown fact from fiction.

Myth #1

High Performance HMI is just a bunch of boring, grayscale, feature-less screens, and it can't make me a better Operator.

Truth: The High Performance HMI standard covers a wide range of topics that simplify the interface, speed operator response time, improve problem and alarm resolution, while reducing errors and mistakes. Yes, color and grayscale are part of the standard, but it's not exclusively about color. It includes things like contextual layout, navigation, shapes, typography, and more...



Myth #2:

I need a complete, real-world representation of the process.

Truth: As the map on the left illustrates the real world can be awfully difficult to

navigate. A more structured view we see on the right allows us to more readily visualize our journey.



When you conduct a web search for optical illusions you will find dozens of examples. They are fun to watch, but more critically, they show us clearly how our brain re-orient visual signals in an attempt to make sense of what we are seeing.

The same principle applies for operators trying to pull out signals from very complex system representations. We need to reflect information in a manner that is easy to scan for anomaly and identify areas that require action.

Myth #3:

My screens are unique to me and my process. High Performance HMI is cookie cutter and one-size-fits-all.

Truth: High Performance HMI is a framework that can be applied to any environment. It is a proven methodology but by no means requires cookie cutter application. As discussed in the first myth, a wide variety of visual cues can be utilized to personalize screens for purpose. Through the use of simple, repeatable shapes and a basic color palette that highlights abnormal situations, HMI Operators spend less time searching

and navigating, and making decisions faster. Keeping it simple also makes it easy to train the next generation of Operator.

Myth #4:

I've been using the same screens for 10 years, I know where everything is.

Truth: After working so hard to get to know traditional screens, it's tempting to accept the limitations they inherently offer. Change can be hard, but we've seen very experienced operators fall in love with the new approach once a comparison was available. Equally important, the burden on training for less experienced operators drops once more intuitive screens are made available. Similar to decluttering your office, High Performance HMI provides a methodology in decluttering your HMI to make an Operator more efficient, more confident, and less prone to error.

In summary, high performance HMI is a proven way to boost efficiency and increase confidence across operator teams. A good interface is easy to learn, leads to faster reaction time, safer operations and higher productivity. You deserve a system that is intuitive - one that at a glance you can see what actions need to be taken and is easy to navigate.

High Performance HMI: Practical lessons for getting started and leveraging data

Our research shows that 90% of companies are collecting industrial data but only 30% are analyzing that data. Even less, just 2%, are acting on the information. With so much money being spent on collecting data, why aren't organizations better utilizing it?

The answer is often simpler than you might expect. Too often, data isn't accessible in an easy-to-interpret way. The good news is this is a barrier we can start removing quickly by following these four steps to enabling High Performance HMI and making important, data-based information jump out.

Step #1

Bring the team together.

High Performance HMI projects with high adoption rates share a common trait. Involving your key stakeholders early on in a project can help solidify the common challenges, explore the best opportunities, prepare requirements and even test user interfaces. Ensure operators are included in this team, they will make or break the success of your program.

Step #2

Build a workshop mentality into your review processes.

It's not enough to bring a group of stakeholders together, brainstorm and then send them on their way. Your stakeholders should have planned review checkpoints to optimize results. These checkpoints are critical for stakeholders to feel part of the journey, raise concerns earlier in the program cycles and ensure there is a high likelihood of agreement.

Step #3

Document and share more.

Write it down, write it all down. This can't be said enough. The advice is so simple, yet it is a step that many overlook. Documenting decisions, learning and work plans is a critical requirement to aligning the team and holding each other accountable.

Step #4

Go after low-hanging fruit

Projects often begin with a boost of excitement but quickly dissipate because the core team gets pulled back into their day-to-day tasks. The most effective path to keeping everyone focused on the long game is to build low-hanging fruit milestones into your project plan. These keep the team motivated and help paint a path to your future vision.

When it comes to designing High Performance HMI, there are a number of design options which should be considered low-hanging fruit improvements. Below are seven options that make a world of difference.

- Replace data links with gauges. A picture really is worth a thousand words. Rather than ask operators to link to data in another location, make it easy for them to quickly visualize what needs attention.
- Display trending objects. Numbers don't always tell the full story. By tracking trends, you can quickly see what might be improving or degrading over time. This will impact the actions taken by operators in both the immediate and long-term time horizon.
- Update piping/other PID elements. Illustrations that mimic piping and other system elements in realistic fashion can make it difficult for operators to quickly isolate issues. Simplify representations and make sure they are accurately depicting the current state of your equipment.
- Remove distracting visual elements. This includes gradient coloring, animations and flashing objects. These design elements distract the operator rather than draw them in to what most needs attention.

- Add or modify background color to improve contrast. It's remarkable how changing the background of a display improves the human eye's ability to process visual information. Our eyes are trained to look for contrast.
- Encapsulate process areas in a card. Make it easy for your team to see related processes next to each other, even if the physical footprint of your solution is separated.
- Consistent fonts, units and naming conventions. Consistency is key to processing visual information. This is a simple fix that can quickly make it easier for operators to focus on what's critical.



Intelligent Alarming

From proactive analysis to guiding operator response, modern alarming technologies use the IIoT's connected systems, layered with new apps, to help eliminate alarm noise and confusion while driving the right corrective actions.

What's the biggest challenge on the plant floor?

According to a recent GE survey, managing alarms is still the biggest challenge.

But, in today's digital age, every organization can manage alarms. With intelligent alarming and the Industrial Internet, companies can send the alarms that matter, when they matter, to the right person. Engineers and operators can receive prioritized alerts with instructions, helping them react to and resolve alarms quickly.



An alarming situation

According to HMI/SCADA experts at GE Digital, about 75% of all alarms are noise. Many companies want to examine their systems and reduce the number of alarms to improve operator effectiveness. However, this is often an endless cycle. Integrators and in-house engineers typically find new alarms that must be added, while looking to reduce the number of alarms and flags in the system.

Too often, companies are forced to accept that there is a level of noise from alarms, and operators must know what to pay attention to and what does not require action. A problem arises with temporary staff operating machines or new operators coming on board. The temporary or new personnel usually don't have the experience to filter through the alarm noise and make sense of it.

Additionally, one problem can cause a flood of alarms hitting an operator. Recently working with a major metropolitan area's transportation team, a proof-of-concept showed how one problem on a train line triggered an initial alarm, followed by another alarm, followed by ten more alarms, then twenty, and the situation continued. The operators on the trains were inundated with alarms and, in this confusion, unable to identify the real problem.



Reduce alarm noise with machine learning

In the Industrial Internet world, today's HMI/SCADA can filter alarms better to increase efficiency. Now, we can use machine learning to look at all the raw alarms in underlying systems, determine a root cause, and guide operators through the right corrective actions. This can take place in a control room or in the field—with instructions going to a mobile device of choice—and deriving intelligence from the raw data.

Machine learning puts traditional alarm rationalization on steroids. HMI/SCADA today, based on the IIoT connected enterprise, can provide full-scope alarm management and optimization, facilitating alarm rationalization by providing visibility to all alarms, the respective alarm priority or tier, frequency of occurrence (for a specified period of time), and more, delivering on an alarm philosophy that improves efficiency, reduces unscheduled downtime, and decreases risk.



Be proactive with analytics

Furthermore, modern HMI/SCADA can add a layer of proactive analysis to deliver predictive intelligent alarming. Today's technology isn't just about delivering the right information after an event has happened, it is also about delivering information before a catastrophic issue occurs and preventing it from taking place.

Consider if a plant monitors a temperature, which exceeds the upper control limit and an alarm goes off. Traditionally, an operator would now react to the alarm. Analytics have made it possible to evolve from being reactionary to now predicting when the event will occur and taking proactive steps.

As an example, a food manufacturer can monitor the temperature data point, put an analytic on it, and predict the temperature based on a statistical model. The company can push an alarm to an operator to ensure that action is taken faster, before a batch is ruined.

This applies to other industries as well, such as pharmaceutical with multi-million dollar batches of product, as well as maintenance events on discrete equipment. The application of predictive knowledge, delivered as an intelligent alarm, is far reaching across all industries and offers new possibilities for consistently optimized operations.

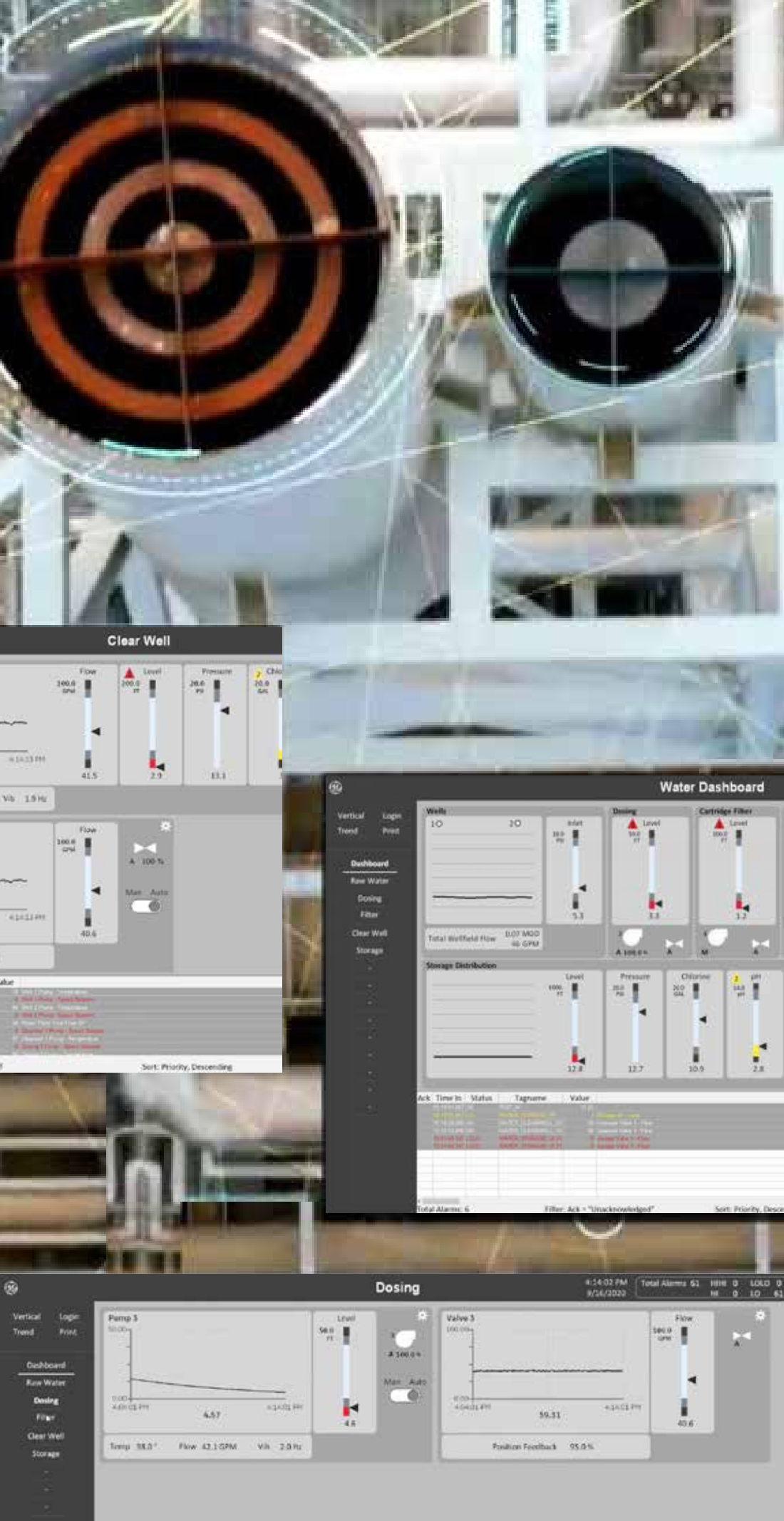

Alarms to the right person, at the right place—in context

Furthermore, our IoT world helps us send alarms in context. This means, once an alarm fires, an operator should be able to understand contextually, not just where in the plant the issue is occurring (from a location standpoint), but more directly, where and when in the process there is an issue occurring.

Operators need to be able to understand the corrective action required to resolve an alarm. As such, seeing that alarm in context is important. In the past, operations teams relied on years of experience for that context—the so called “machine whisperer” who understood that if “x alarm” occurred under “y circumstances,” then it meant a conveyor, for example, was moving too fast and they knew exactly how to tweak a dial. With our changing workforce, those days are gone—and digitization must be the foundation for providing the context to newer, inexperienced workers.

Lastly, HMI/SCADA gets the alarm, in context, to the right person in the right place. Organizations can deploy alarms to

an operator, engineer, or manager based on role and physical location. As an example, an engineer is standing on Floor 4 in front of a mixer and an alarm triggers related to a machine on Floor 1, which is 25 minutes away. Does it make sense to deploy the alarm to that engineer?

Today’s HMI/SCADA system can determine that a colleague is standing 100 feet away from the machine in alarm—and instead send the signal to the closest engineer for faster, more efficient response.

The right information, in context, finds the right person in the right location, which is drastically different from the traditional SCADA world and drives faster action.

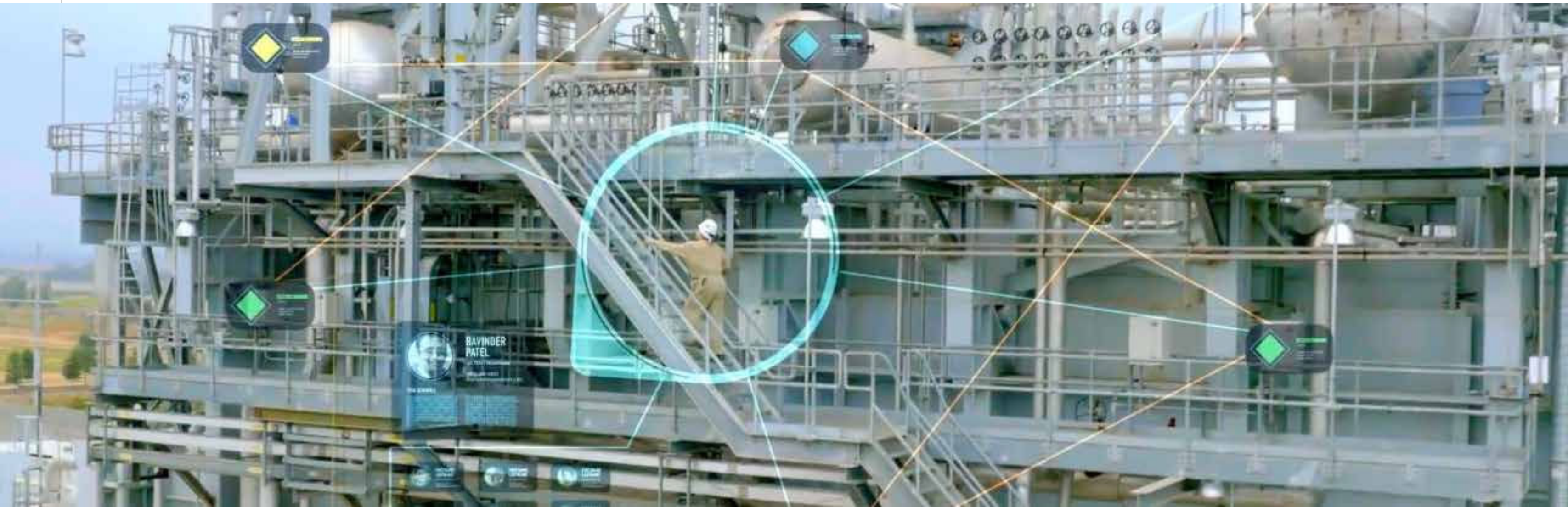

Smarter operators with intelligent alarming

Today's HMI/SCADA is not just monitoring and visualization, with alarms rolling in. For operators, HMI/SCADA is their decision support system, and intelligent alarm management is critical. Here are two golden rules to think about:



Don't allow technology to complicate the operator experience.



Use technology to improve the operator experience and manage alarms for greater efficiency.

With just a glance, operators should be able to recognize which information requires their attention and what it indicates. You can enable smarter operators with intelligent alarming for faster alarm detection, greater understanding, and improved business outcomes.

Take operations to the next level with GE Digital's proven HMI/SCADA solutions.

Join Us Today



HMI/SCADA and Industrial Data Management

Data is the foundation for delivering outcomes, data historians provide the common thread. This supports organizations to drive IoT initiatives, process and equipment analysis, compliance reporting, and more.

In addition to a data historian, another key component to turning data into information is via an asset model, to provide context that personnel of all levels can understand — from the plant floor to the operations center.

“For us, the first step in creating information is putting the data that has been collected in a context everyone in the organization can understand.”

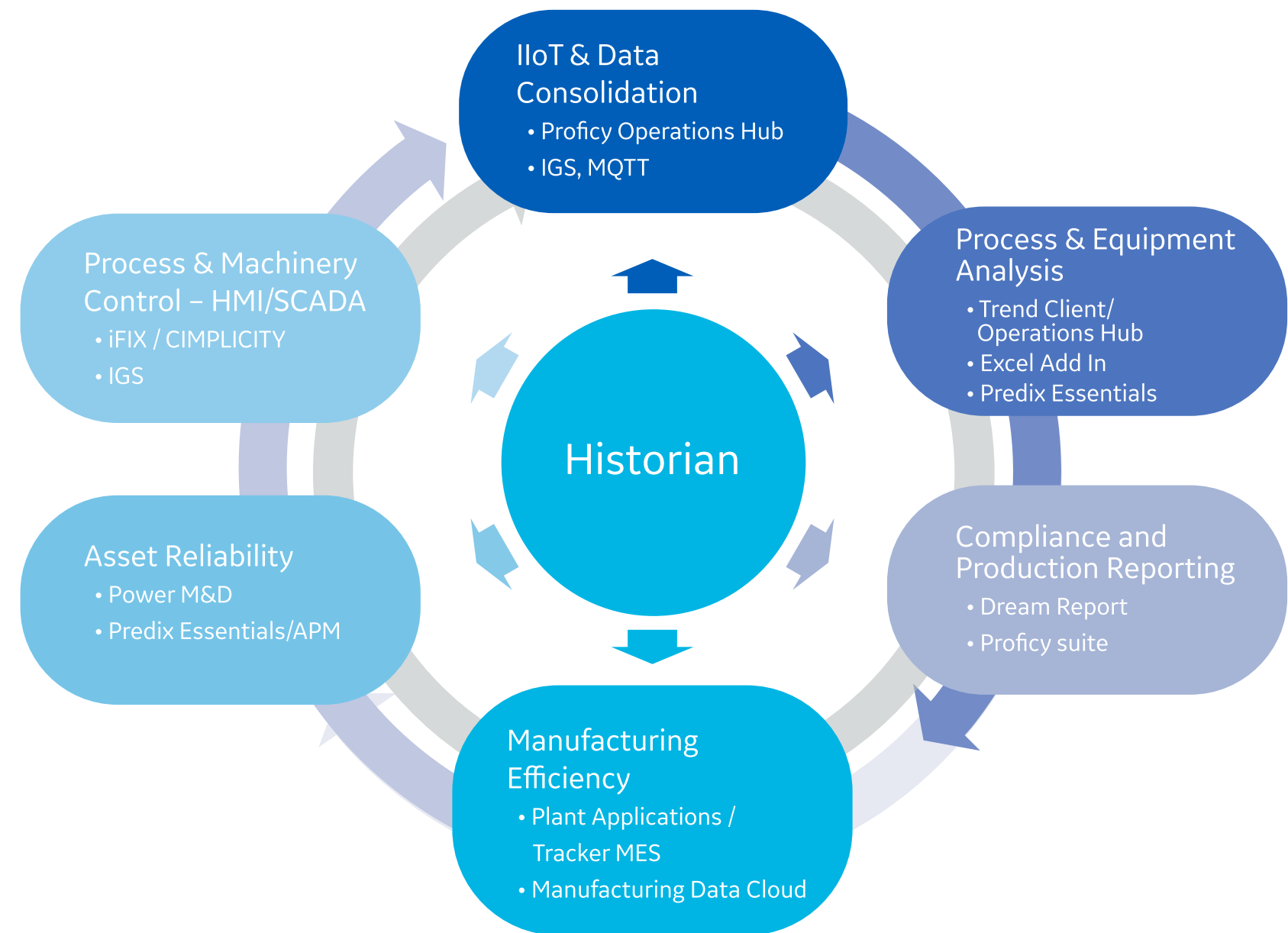

HMI/SCADA + Data Historian Deliver the Foundation for Digital Transformation

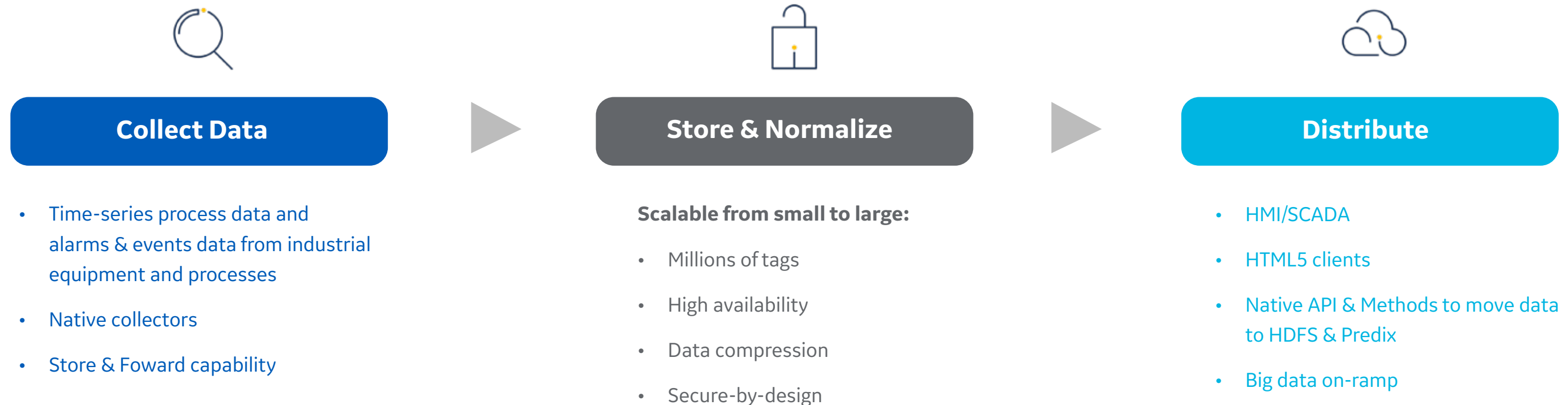

Organizations need the ability to aggregate near real-time data from sensors along with historical data from ERP systems, quality systems, HMI/SCADA, and other data sources. In addition, users need to know the data is clean, valid, and high quality.

At the core of data management is a plant—or enterprise-wide data historian, that facilitates data collection, storage and normalization, and distribution. It stores time-series process data and alarm and event (A&E) data from

industrial equipment and processes. Data can be collected from hundreds of different types of control systems and should be scalable from a small set of data tags to millions. Data should be distributed from a data historian by an integration with HMI/SCADA clients, through HTML5 clients, or via APIs.

“The nice thing about Proficy Historian is it lets organizations start very small and have a roadmap to long-term and very robust and intense data analytics.”

Centralized Visualization: HMI/SCADA and Beyond

Visualize and Share Data to Derive Value

To provide customers with a data management solution that has both asset model context and visualization, GE Digital developed Proficy Operations Hub, which integrates with historian technology such as Proficy Historian, HMI/SCADA such as iFIX and CIMPLICITY, as well as other systems. This combination enables manufacturers and utilities to unlock the value in their data through shared information and collaboration as well as rapid application development (RAD) tools.

What's the value of data if it can't be shared and visualized across a plant and enterprise?

Proficy Operations Hub is an industrial application platform for aggregating data from multiple sources. Proficy Operations Hub's code-free environment allows industrial applications to be rapidly built and deployed. It enables improved plant operations through comprehensive information that is easier to analyze and act upon. Key aspects include:

- Connecting to all systems in a multipurpose, multi-use plant and enterprise
- Democratizing tools so they are accessible throughout the organization and easy to use by all
- Visualizing data across all levels of a network
- Scalability in being useful for both small initiatives and massive undertakings

Connectivity is critical, and some methods include OPC UA, MQTT (Message Queue Telemetry Transport), and REST APIs.

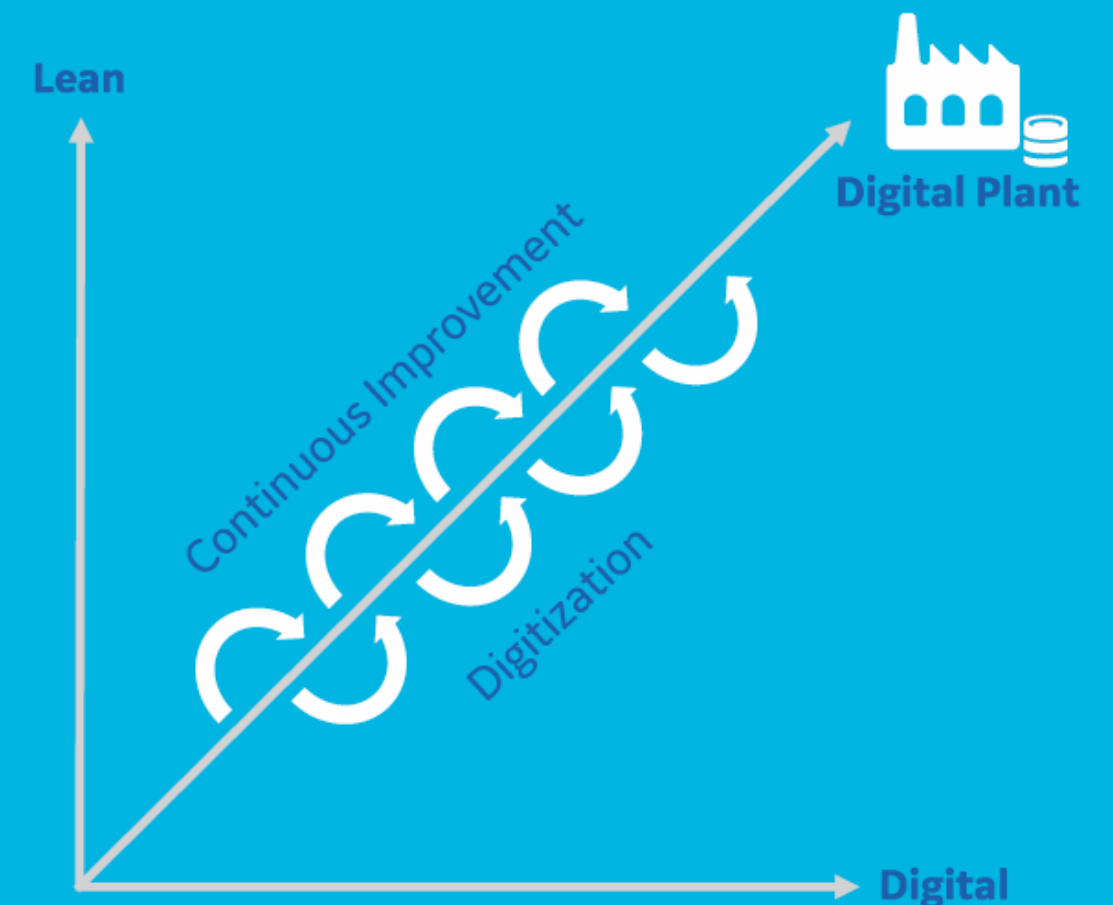

“A key part of our belief is that tools have to be democratized . . . we want the tools to be accessible and usable by everyone.”

Contextualized Data is the Basis of Digital Transformation

If I'm an engineer, I need to know about my equipment. How many pumps are in the field? What kind of equipment is on Line 1? What's the status of all of my packaging machines? How is the bearing temperature of Motor 1 compared to Motor 2?

This is data in context versus tag names with values in my system. I need the data to tell me what I need to know, when I need to know it and in a centralized environment that enables me to act upon that data anywhere, any time.

IoT needs ten times the data in today's changing industrial landscape. Sensors are cheaper, so they are easily deployed in multiple scenarios. High speed networks provide the ability to manage huge amounts of data that come from those sensors at a reasonable cost. Unprecedented computational power through the cloud and the proliferation of mobile and touch interfaces increase the amount of data available.

Digital transformation is a journey. Companies worldwide are looking to connect, collect and store, visualize and analyze, and optimize their data. They are looking for solutions that can connect, aggregate and visualize their data across multiple assets to drive down operational costs and achieve consistent quality in their plants – regardless of industry.

The visualize and analyze piece is where companies are looking to Democratization of Data to unlock the value of existing data. How do we pull in non-traditional data, historical and data from other systems? Contextual data analysis gives you a view that you didn't have before. An operational view. How do we enable this?

Proficy Operations Hub is a new solution from GE Digital that offers centralized visualization/configuration, digitized processes and democratized digital tools to enable collaboration and continuous improvements. It provides visualization enabled across all levels and roles within the plant and enterprise for business intelligence.

A democratized tool in the hands of all plant users enables them to increase operational efficiency and make better decisions based on comprehensive information – real time, historical, automation and MES, and third party – that's easier to analyze and act upon independent of location.

As one example, a customer has employed Proficy Operations Hub to democratize their digital tools within the plant. Managers and supervisors promote KPIs to plant dashboards to be seen and be accessible by all employees on the plant floor. Users create KPI trends, dashboards and favorites to monitor utilities. All users in the plant use the tool to analyze, troubleshoot and monitor operational information through a timeline of events and then share dashboards that result in improvements, which ultimately benefit the business.

Increased visibility into production process status and progress in real time enables continuous improvement through digital tools. Unlock your operations intelligence to realize optimized plant operations.



Asset Models for Context

Enable more employees to make better use of the data being collected



What does the tag ALB_BLDG1_L1_M47_DISPUMP1_RPM mean?

We often hear statements like “we only get value from 5% of the data collected.” New approaches help industrial organizations overcome the challenges of getting real value from the data being collected.

The first step in turning data into information is creating context for the data.

What does this mean?

Whether data is from an HMI/SCADA system (collected from PLC memory locations), time series and Alarm and Event data from a Historian, or IoT sensor data, industrial data is typically identified by a “tag name.” People that work with the data every day may understand how these “tags” correlate to signals coming from the plant equipment or other sensors. The problem is that set of people represents a small percentage of the people that could potentially get value from the data.

The answer is to create a mapping between the tag data and a representation of the machine/line/plant.../enterprise – called an asset model. Any user who wants to know the value of any specific sensor (such as RPMs of a pump) can find the specific pump in the model and see the data values associated with the pump, RPMs in this example.

Asset modeling today includes the ability to create standard object types (think templates) that include the standard set of information associated with a type of equipment. Having standard object types (templates) that can be referenced for each similar piece of equipment further enhances users’ ability to understand the plant equipment. Comparison of the parameters associated with multiple examples of a given equipment type becomes simple.



So what does the tag ALB_BLDG1_L1_M47_DISPUMP1_RPM mean?

Probably only a few people know the answer. However, almost everyone can understand what the RPM parameter for the discharge pump number one on Mixing Machine 2 in Building 1, Line 1 in Albuquerque means. And if they want to compare the behavior of Discharge Pump 1 and Discharge Pump 2, no problem. Context makes all the difference.

Putting information (Data in context) in the hands of every user

One of the fascinating impacts of the age of IoT is the merging of two trends – a workforce of digital natives that are comfortable with technology and technology toolsets that simplify the task of creating applications that show operators the right mashups of information from various business systems, on their device of choice.

The newest generation of web technology based application development tools are designed with the following capabilities:

- Drag and Drop, code free application building
- Mobile operator support, including responsiveness to device type (desktop, tablet, phone, smartwatch)
- Asset model context for data and analysis tools
- Security features allowing control of data visibility and application functionality (read only vs read write, for example)
- Unlimited developer and runtime licenses

The combination of easy to use tools and data in context of an asset model has created an opportunity for individuals to create web-based applications that show plant data in the way they want to see it. Individuals can build mini apps (web pages), link them together, and share them amongst their peers. Since the mini apps are asset model aware, other users that manage similar assets elsewhere in the organization can use the mini apps unchanged by navigating to the asset they manage within the context of the app and asset model. All of this is possible within the network and IT security infrastructure that exists within plants today.

This ability for the individual to explore, create, test, modify, and share tools that enable better outcomes represents a sea change from the current paradigm where system design is managed by a few “experts.” DCS’s, HMI/SCADA’s, historians, and even operator interfaces – all require a level of expertise, access to development tools, and change management processes. For these operational systems, the engineering practices are applied to systems that interact with plant equipment. The new generation of tools is designed to interface with these source systems and other data sources (smart sensors, other business systems) to provide information which enables better decision making in a novel way.

For companies looking to accelerate their digitization journey and take advantage of the skills of the new digital native generation of employees these new web technology-based tools can play a key role in achieving these goals.



Understanding and Minimizing HMI/SCADA System Security Gaps

Introduction

Being at the heart of an operation's data visualization, control and reporting for operational improvements, HMI/SCADA systems have received a great deal of attention, especially due to various cyber threats and other media-fueled vulnerabilities.

The focus on HMI/SCADA security has grown exponentially, and as a result, users of HMI/SCADA systems across the globe are increasingly taking steps to protect this key element of their operations.

The HMI/SCADA market has been evolving with functionality, scalability and interoperability at the forefront. For example, HMI/SCADA software has evolved from being a programming package that enables quick development of an application to visualize data within a programmable logic controller (PLC) to being a development suite of products that delivers powerful 3-D visualizations, intelligent control capabilities, data recording functions, and networkability.

With HMI/SCADA systems advancing technologically and implementations becoming increasingly complex, some industry standards have emerged with the goal of improving security. However, part of the challenge is knowing where to start in securing the entire system.

The purpose of this chapter is to explain where vulnerabilities within a HMI/SCADA system may lie, describe how the inherent security of system designs minimize some risks, outline some proactive steps businesses can take, and highlight several software capabilities that companies can leverage to further enhance their security.

SCADA security in context

The International Society of Automation (ISA) production model demonstrates the layered structure of a typical operation, and shows that HMI/SCADA security is only one part of an effective cyber-security strategy. These layers of automated solution suites share data, and wherever data is shared between devices, there is a possibility for unauthorized access and manipulation of that data.

This chapter concentrates on the HMI/SCADA layer, but unless other potential weaknesses at other levels are covered, the operation as a whole remains vulnerable.

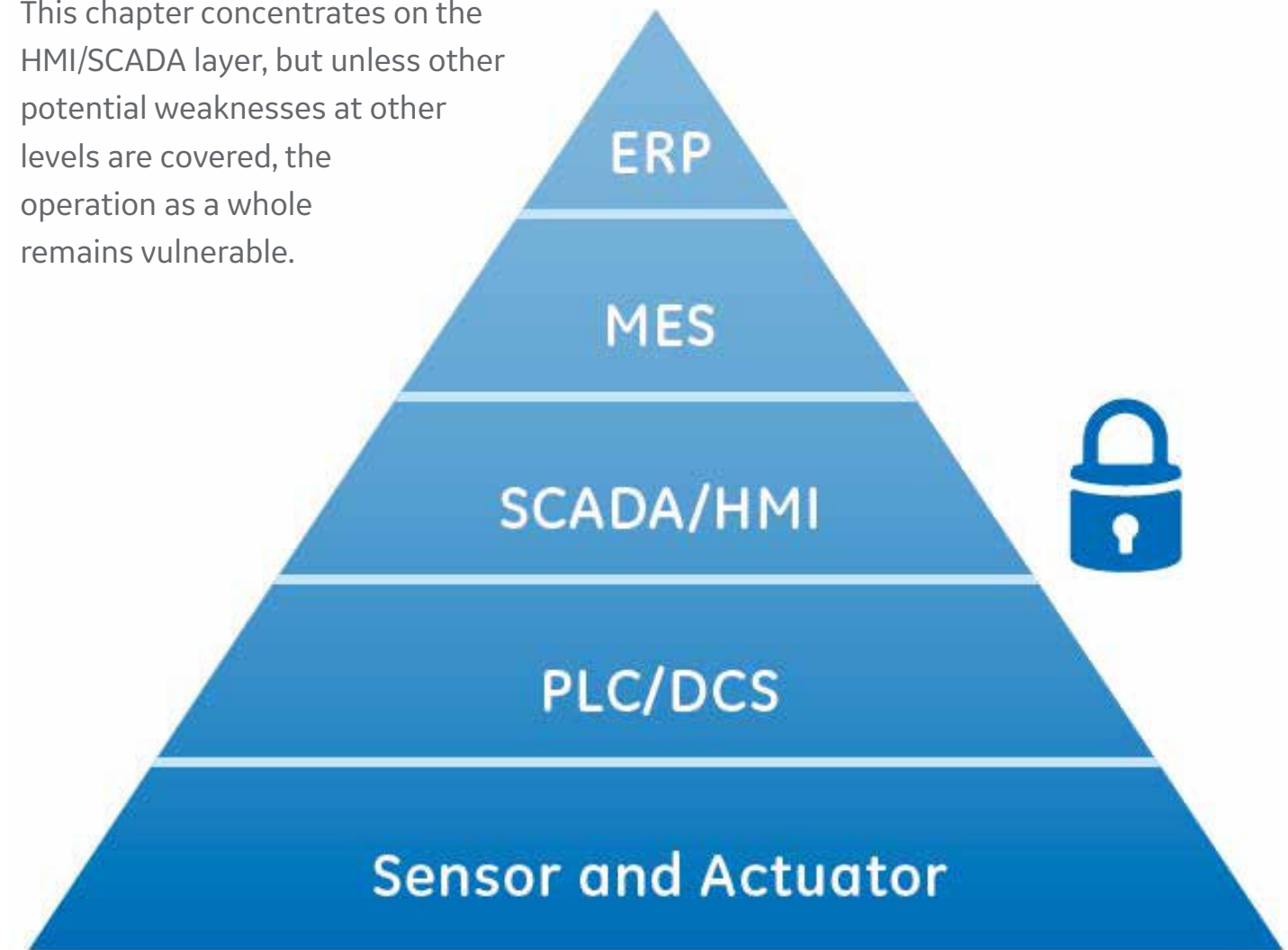

Component vulnerabilities within an HMI/SCADA system

To minimize existing security gaps, companies need to first understand where potential vulnerabilities typically lie within the system. Powerful software features, along with the advancements in automation hardware and industrial communications, have made control systems multi-layered, complex and susceptible to threats. An HMI/SCADA system's level of security is best understood if broken down into two major elements: Communication and Software Technology.

Communication

Communication advancements have made large-scale HMI/SCADA system implementations successful for many industry applications. There are two levels of communication that exist within the system—information technology (IT) and the field, which have notable security level differences.

IT - Components of an HMI/SCADA system are modular, not only to allow for easy troubleshooting but also to distribute the computing load and eliminate a single point of failure. It is not uncommon to have multiple thick, thin, web and mobile runtime clients connected to the main HMI/SCADA server hub over an internal Ethernet-based network; however in some cases, systems may use

external leased lines, modems, wireless, cellular, or satellite technologies as well.

The main HMI/SCADA server hub also consists of multiple networked servers to distribute the load, ensure uptime, and store the mass amount of data. With these components all networked in some way, they use standardized common protocols to transfer data—all of which are largely unencrypted, requiring weak or no authentication.

Field - HMI/SCADA implementations frequently consist of a number of widely dispersed remote sites with a control or data gathering function, all connected to a central control and monitoring point. Data has to be passed between the control room and the remote terminal units (RTUs) over a network (which may be fiber optic, telephone or wireless), and the protocols for passing this data have frequently been developed with an emphasis on reliability and ease of implementation rather than security.

Modern computing facilities have made secure practical encryption almost impossible to defend against a determined hacker, so communications between devices need to employ several layers of defense with the primary aim to make access to the data difficult, and detect if the data has been compromised.



Software technology

Software over the years has largely become feature-bloated as companies keep adding new capabilities while maintaining all of the existing ones, increasing the complexity of software security. There are two separate but dependent software technologies in the system, the HMI/SCADA software and the Platform Operating System, which have distinct differences when it comes to security.

HMI/SCADA Software – Most HMI/SCADA software installations have either external network connections or direct Internet-based connectivity to perform remote maintenance functions and/or connect up to enterprise systems. While these types of connections help companies reduce labor costs and increase the efficiency of their field technicians, it is a key entry point for anyone attempting to access with a malicious intent.

Platform Operating System – Operating systems that employ elements of consumer or “open” source operating systems such as Windows Server, Linux and Unix variants are increasingly popular since they help reduce costs. This trend toward open technologies has made proprietary custom, closed, highly secure systems a direction of the past, but it increases the risks.



Also, due to the fact that HMI/SCADA systems are complex and contain multiple layers of technology, even a simple system patch is a major undertaking that requires planning, funding and time. The risk elements are also substantial because many systems now rely solely on their HMI/SCADA system for visualization, data recording and some control elements. And to this point, some companies hold back on patches, service packs and upgrades, while others choose not to apply any new patches, employing a “it works, don’t touch it” policy. Furthermore, software patches have generally been developed to cover for a security breach that has already occurred.

Some would say that even if companies could keep their platforms current, with the fast pace of consumer-based operating systems and large number of system exploits, platform operating systems are the single largest security risk in the system.



The inherent security of system designs minimizes some risks

The good news is that some vulnerability is minimized by the nature of system design and HMI/SCADA software design, whereby the fundamental principles and canons of engineering mandate safe and reliable systems. This ensures a basic level of security to protect against an intruder.

Engineers design systems with intentionally broken automated chains—meaning in some cases functions require physical confirmation prior to the software performing commands and in other cases, the SCADA software only does a portion of the command, requiring one or many additional manual steps to execute the function. Inherent system security is best surmised at the software and hardware levels.

Software: With many viewing HMI/SCADA software as a visualization tool that provides a means for dynamic operator input and visualization as a flexible information terminal, the reality is that HMI/SCADA software capabilities are much more exhaustive. When elements are added such as control and logic capabilities, system engineers must examine the risk from a potential failure standpoint and the extent of control that is allowed without being in line of sight of the area being controlled.

Software is also developed from the operator's perspective and uses company guidelines throughout the application to ensure the operator is controlling with intent. While this doesn't necessarily bring additional security from external intruders, it does provide enhanced protection against mistakes. For example, the "select before operate" design philosophy is typically used in HMI/SCADA applications, which requires the operator to select an item on the screen, pull up the controlling elements, operate the item, and finally confirm

to send the command. While this may seem like a simple ideology or a drawn out process, this intentional design ensures that an operator's actions are deliberate as opposed to a hasty reaction to an urgent situation.

Hardware: At this level, design engineers employ many techniques to ensure safe control, either physically or by the HMI/SCADA software. Thousands of individual devices and RTUs can exist in a system and are typically implemented with an area-based manual or automatic control selection; field technicians use manual control to perform maintenance or to address a software failure—locking out the software control and establishing local control.

Additionally, when engineers design this level of the system, many hardware-based fail-safes are built in the design such

as fusing or hardwire interlock logic to examine the local situation, so when components are commanded by the HMI/SCADA software, there is a hardware level of checks to ensure it can be executed. This protects the system from unsafe or even incorrect software control. Furthermore, many critical applications use triple and quad redundant logic controllers to ensure continuous operations.

Taking into account the general design rule that system engineers apply for all levels of a system can be surmised by "if a single point of failure exists, protect it or provide secondary means." Therefore, design philosophies typically drive a holistically safe and secure-by-design environment, which can severely impede an intruder's ability at the HMI/SCADA level to impact the entire system.



Inherent Security Examples

1. Manufacturing and Part Movement

- a. An HMI/SCADA system is programmed to command an automated gantry to move manually.
- b. To move the automated gantry, the HMI/SCADA “soft” button must be engaged as well as separate manual pushbuttons.
- c. The automated gantry system is also interlocked with photoelectric sensors, and will not move if it detects any object within its operating area.
- d. Additionally, there are two physical mats on the plant floor outside the operating area within line of sight of the gantry on the plant floor—one in front of the HMI/SCADA terminal and one in front of the manual pushbutton station. These mats have built-in sensors to ensure that someone is physically present prior to operating.
- e. All conditions must be true for the automated gantry systems’ manual functions to be powered up and engaged. This type of system design is largely for the safety of the workforce, but also ensures that hackers cannot independently operate this function if they have control of the HMI/ SCADA system.



2. Water Treatment and Chemical Control

- a. An HMI/SCADA system in a water treatment plant is the main control point for chemicals being added to the water.
- b. One of the key chemicals controlled by the HMI/ SCADA system is chlorine. Excessive amounts of chlorine could be hazardous to public health, and conversely too little can also put people in danger, so engineers have designed a level of safety into the automation system.
- c. While the HMI/SCADA system controls the main chlorine values, downstream chlorine meters continuously measure the concentration level and have the ability to cut off the chlorine addition in the event of abnormal levels.
- d. The metering control elements are isolated from the HMI/SCADA control with the only interaction between the systems being a one-way alarming connection to annunciate in the event of abnormal levels of chlorine.
- e. Additionally, water treatment facilities are mandated to frequently test the chemical makeup of the outgoing water. The system’s operators analyze the test results daily and have the ability to cut off and bypass the chemical systems based on the test results.
- f. With this multi-tiered automation and manual ability designed into the system, the system as a whole has an inherent level of security against rogue remote control and malicious attacks.

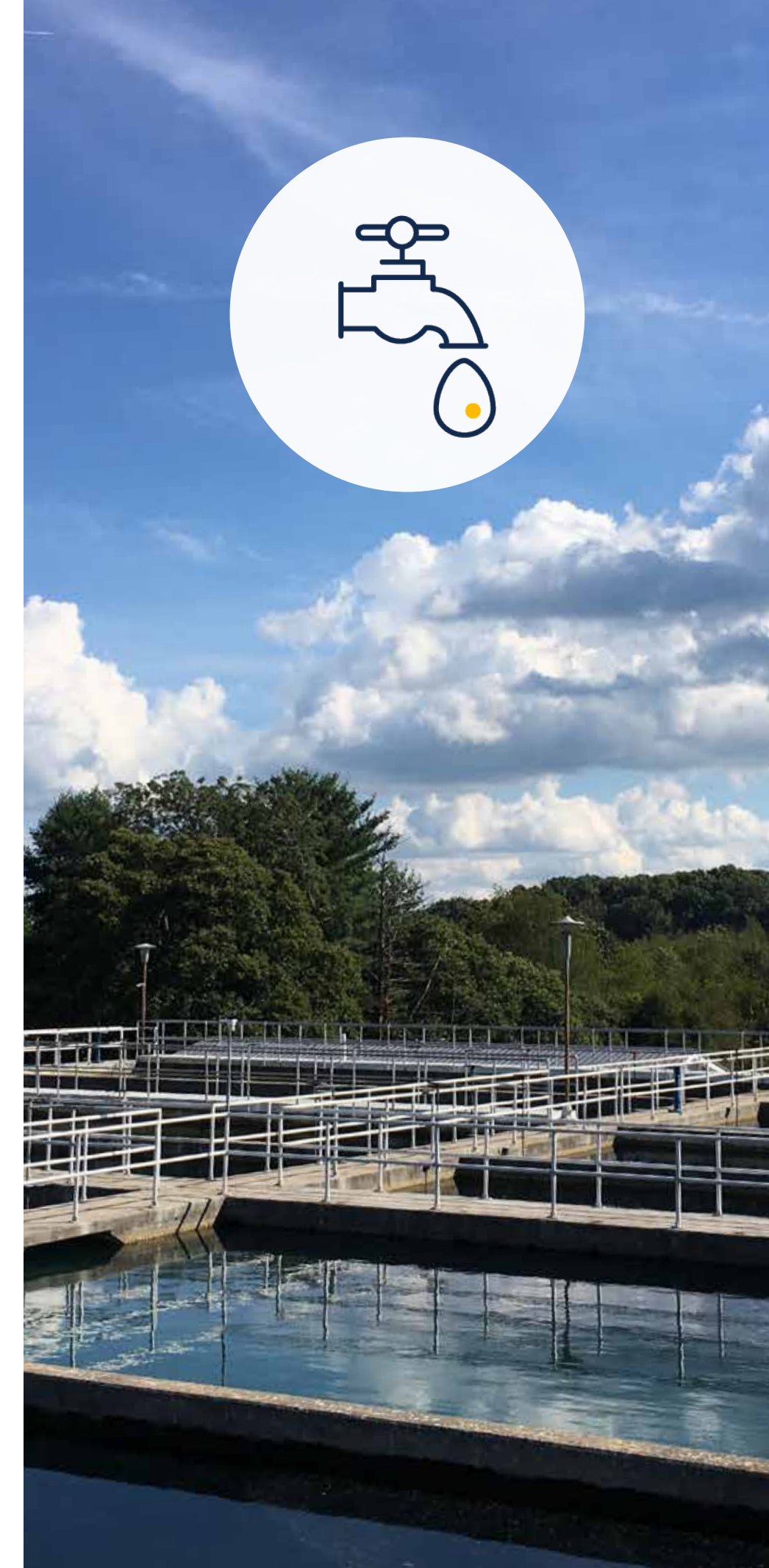

Considerations to critically examine your system

1. Examine your field assets, particularly older, remote components

- How does the SCADA communicate with them? Can this be secured?
- Is the control network adequately separated from other networks?
- Where are the points of entry/failure? Are there redundant options?

2. Examine your IT assets

- Are the services/software running on an asset the minimum needed to maintain functionality?
- How secure is that software and does the software employ passwords, biometrics or retina protection?
- Do you have easy access to the operating system and SCADA system patches? Is this performed regularly?

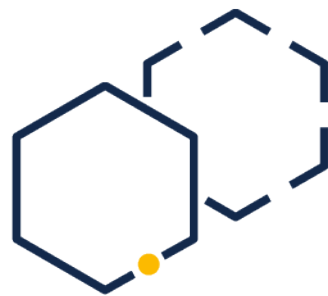

3. Examine your change management software policy

- What is the policy for implementing an operating system and SCADA patches – does it cover all assets?
- Are all assets protected (covered by firewalls and anti-virus software)?
- How easy is it to manage user accounts across all layers of software – is there an integrated system that includes the operating system and software products or does each product have separate user accounts and passwords?

4. Examine your access control

- Does your SCADA software allow anonymous client connections?
- Is there a robust login policy with regular renewal of passwords?
- Does each user have an appropriate limit to their actions?

Be proactive: Enhance your security with software capabilities

However, even the safest system design and industry standards cannot secure a system 100%, and therefore, companies should not rely on them wholly to protect their systems. Instead, they should take a proactive approach to enhancing security, and a good

starting point is knowing what technologies are available to help them best meet their needs.

Selecting a trusted solution provider with deep expertise, experience and advanced technologies is also critical. Off the- shelf solutions such as GE Digital's iFIX and CIMPLICITY HMI/SCADA software have successfully helped companies minimize their security gaps with a broad range of security-based software technologies, including:

- **Biometrics** – When bio-security elements are integrated to the system, customers can program their system to require finger scans to perform specific functions such as switching on and off the grid's main switch gears, which ensures that the appropriate person be physically present to execute the order. This type of integration eliminates the possibility of a hacker performing the same operation virtually—reducing the overall potential impact and enhancing the overall system security.
- **Electronic Signature** – Many view this option as a simple reporting tool, however the features are much more comprehensive. For example, it can introduce authentication potential at the command level to verify the user performing the operation with a username and password as well as a separate authentication, typically a manager, for verification. The information is then stored in a system audit trail

that can be recalled in the future; some customers also choose to integrate this feature with biometrics to eliminate the use of a single, widely known username and password.

- **Authorized Connections & Client/Server Data Encryption** – Many off-the-shelf HMI/SCADA software products now have built-in features that limit the allowable client connections to known computers and use integrated data encryption for client communications. This protective capability eliminates the possibility of a hacker simply loading the HMI/SCADA client and connecting over the network.
- **Domain Authentication** – To leverage complex alphanumeric passwords at the HMI/SCADA level, some software packages offer an add-on capability that introduces Windows® Domain Authentication security integration. For example, GE Digital features an application add on that maps group memberships to its HMI/SCADA software roles and when integrated, the users and subsequent passwords are managed at the IT level. This allows for the HMI/SCADA application to leverage existing group IT-level policies, which are typically very stringent and can exceed industry requirements.

Investing in system security in today's business climate

Improving an overall system's security can be a costly endeavor, and companies must find the right balance between spend, design and process to make their systems safe. This is especially true as companies face increasing cost reductions mandated in today's challenging economic environment. In response, off-the-shelf HMI/SCADA vendors have developed industry solution packs that include specifically tailored tools to help reduce development and overall system costs.

For example, GE Digital offers several solutions with complete, pre-developed, HMI/SCADA drag-and-drop elements, graphics, toolsets and configuration tools that significantly reduce both the initial and ongoing costs associated with HMI/ SCADA software. Companies can then re-route the resulting cost savings into additional security software and hardware to augment the inherent safety of their systems—reducing overall vulnerability.

The cost of implementing an HMI/SCADA security policy should also be evaluated against the risk of a security breach—in terms of reputation, liability and intellectual property. Companies may discover a proactive approach actually reduces overall costs by ensuring business continuity when compared to the potential operational and financial loss that can occur due to the exposure of an unprotected system.

*Always refer to your software provider's
Secure Deployment Guide.*

Conclusion

The vulnerabilities of HMI/SCADA systems can pose a serious threat, and the complexity of multi-layered technologies can make it difficult to completely secure one's operation. As discussed in this chapter, the inherent safe design of most HMI/SCADA systems offers some protection, but they are by no means enough to fully protect systems.

That's why it's important for companies to better understand where vulnerabilities exist within their systems and to take a proactive approach to address those susceptible areas. Off-the shelf HMI/SCADA vendors offer software solutions with security based capabilities, which can help companies enhance the protection of their critical infrastructure assets and reduce costs for a sustainable competitive advantage.





HMI/SCADA Case Studies



Korea Water Resources Corporation

K-water works with GE to realize the optimal solution for the global water industry, providing the highest efficiency and quality





Since its establishment in 1967,

The Korea Water Resources Corporation (K-water) has worked toward more efficient development and management of Korea's water resources.

To that end, they are continuing the aggressive pursuit of change and innovation in water management practices as the next big step towards becoming "a global water environment specialist."



K-water started a journey with GE to develop a centralized and integrated water solution for all over the world as Water-K, an OEM brand name for GE Digital's iFIX HMI/SCADA for the automation of water supply facilities and the standardization of water treatment process, and K-water renamed it as iWater and exports to the companies in the water industry across all over the world.

K-water has managed **56 water control facilities** including 20 multi-purpose dams, 16 multifunctional weirs, and the Nakdong River Estuary Bank, to provide a clean and stable water supply. In addition, K-water has built 48 wide-area and industrial water supply facilities with a daily supply capacity of 17.6 million m³ and currently supplies drinking water to 22.3 million Koreans.

K-water has been entrusted to operate the water supply systems for 23 local governments, starting with Nonsan and most recently Cheongseong by using iWater.

K-water supplies industrial water of various quality of levels, customized to the needs of customers, and is becoming Korea's leading supplier of water for industrial purposes thanks to the development of high-efficiency, low-cost water treatment process and the optimized automation and centralized integration of its data by using our system.

Lastly, K-water treats 12.8 million m³ of sewage per day to improve the water quality of streams and enhance public hygiene, thereby creating a better living environment. K-water is managing the entire country by dividing into 3 regions along with the rivers such as Hangang River Regional Head office, Nakdonggang River Regional Head office and Geumgang, Yeongsangang & Seomjingang Rivers Regional Head office. By using iWater, K-water has moved beyond

the simple management and utilization of water and achieved integrated water resources management of these regions' water supply systems and local water supply system throughout the entire South Korea by applying ICT to the management of water quality and ecology. Thereby it allows equal distribution of the benefits of water to everyone, everywhere.

Success of the integrated water management system is the key to national water safety and public water welfare. K-water promises to provide healthy water circulation for all to protect citizens from disasters such as flood and drought and ensure greater happiness through the sharing of water.

The company is working tirelessly to develop and manage water resources in an environmentally friendly and efficient way.

- Drinking water for 22.3 million Koreans
- 56 water control facilities
- 20 multi-purpose dams
- 16 multifunctional weirs
- 48 wide-area & industrial water supply facilities
- Daily drinking water supply of 17.6 million m³
- Daily sewage of 12.8 million m³
- 23 local governments





Their goals include:

- To promote the integrated management of water-related facilities
- To establish seamless flood control and irrigation systems by leveraging information technology
- To produce and supply the world's safest and best tasting tap water
- To further expand into international water markets
- To increase their social responsibilities as a government-run company

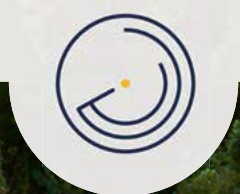

Long-Term Partnership with GE

To fulfill their goal of being a global company specializing in water resources, K-water wanted to find the best business partner for a specialized software application to offer as an OEM solution in the water industry.

“When we selected the software for the water system, we considered who had the largest number of installations and who had the best reputation in the water industry throughout the world,” explained the IT Manager for K-water’s Water Supply Division.

K-water determined that they needed specialized software to eliminate the concern for water-related disasters and environmental issues while also promoting the fair distribution of benefits from clean, safe water.

“GE has provided stable and sustainable solutions for many years without any defects for K-water,” Water Resources Management Division Manager said.

In the result of the company’s effort to develop and manage water resources in an environmentally friendly and efficient way, K-water’s integrated water management system, iWater, is widely used not only in Korea but also in other countries such as Algeria, Indonesia and Thailand.

K-water is taking the experiences and wisdom built up over the past 50 years as a precious resource. K-water will take the lead in solving the water issues, which are urgent matters in Asia and around the world.

Integrated Water Monitoring System

Considering all factors influencing water management in each basin, K-water carries out water resources management through the integration and intelligent management of water quantity, quality, ecology and environment, which were previously managed separately.

K-water, as Korea’s only organization with the capability to deal with all fields of water resource surveys, including surveys of sluices, basins and groundwater, provides to the public all water-related data collected in real-time through iFIX as its main HMI/SCADA system for iWater, as the company’s water resource management system. Also, the company is building an intelligent water operation system that collects operation data on the whole water supply process, from the intake source to the tap, and carries out real-time monitoring and control.



- Technology Supported Projects
- Investment Projects
- ODA Projects

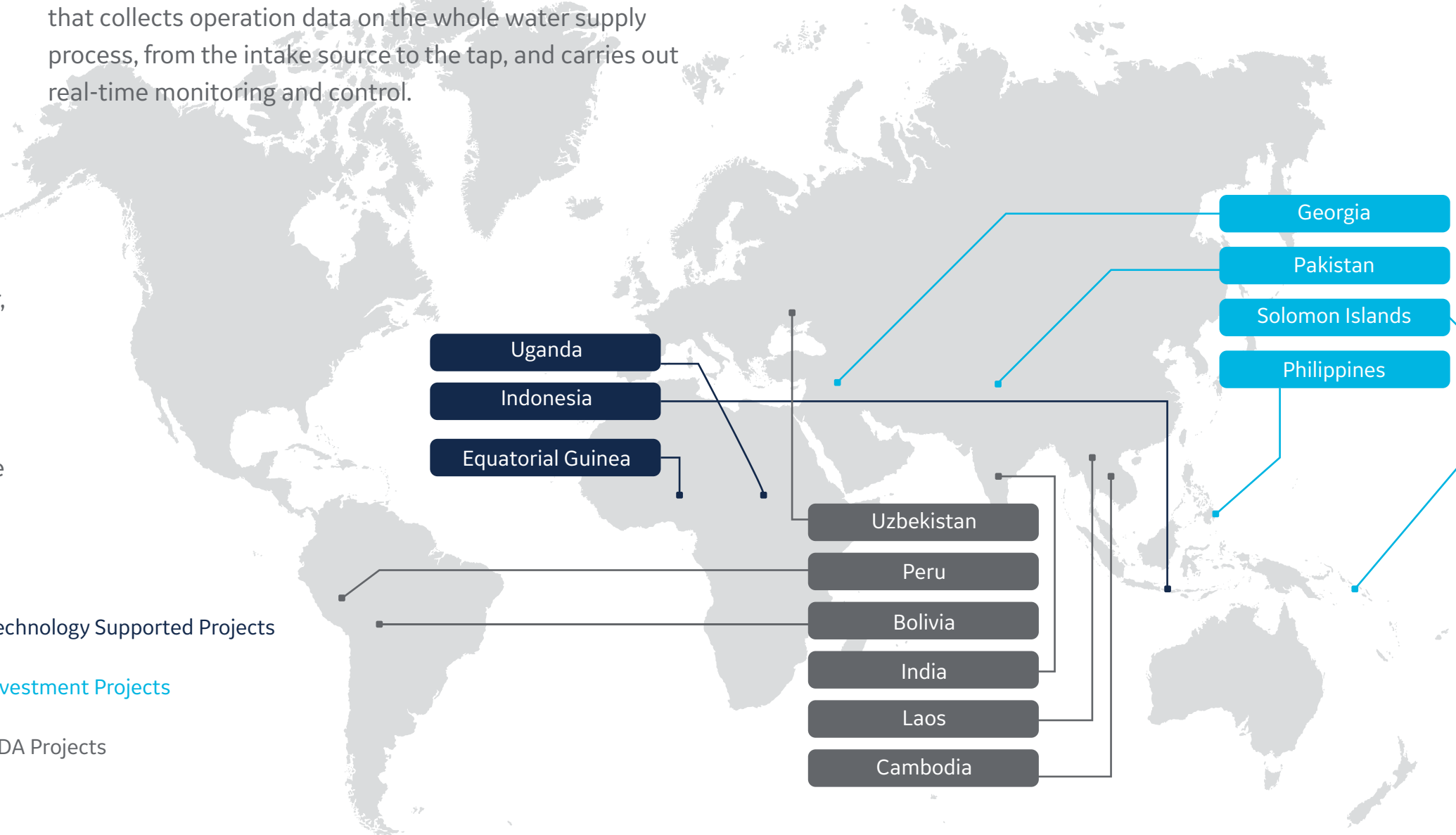

iFIX is part of the Proficy family of automation software products, a single intelligent production solution that works with existing multi-vendor hardware and software solutions to gather and analyze data. Solutions can connect to equipment across the entire physical enterprise to deliver both on-line monitoring for rapid operational response as well as collect historical data as the foundation for continuous improvement. So, K-water can implement many other useful programs by using the third-party interface of iFIX.

“Compared to other HMI, it is possible to operate a wide range of operations from the perspective of the operator and system integrator. iFIX provides a friendly development environment for the engineer so that we can easily customize and use it. It supports various interfaces such as VB Script, .NET API, Dynamo functions and AlarmQ functions so that we can develop complex requirements of operating personnel,” Hong Jintaek, System Integrator developer for K-water, said.

iFIX offers canned functionality to drill into tag details, instantly trend variables, view enterprise data through hosted portal displays and deliver thin client connectivity to SCADA nodes through terminal services. Graphic tools deliver a variety of drawing productivity tools and advanced capabilities for 3D piping and connected object management.

“iFIX supports Standard Dynamos. Using Dynamos, various objects such as pumps, valves, and tanks used in K-water are developed in the form of a ‘standard dynamo’ and delivered to operator and developer to design the screens based on this. Even though many people design various screens, it looks like one person designed them because of Standard Dynamos. The biggest advantage is that operators can work without a hand-over even if the workplace is changed,” Hong Jintaek, System Integrator developer for K-water said.

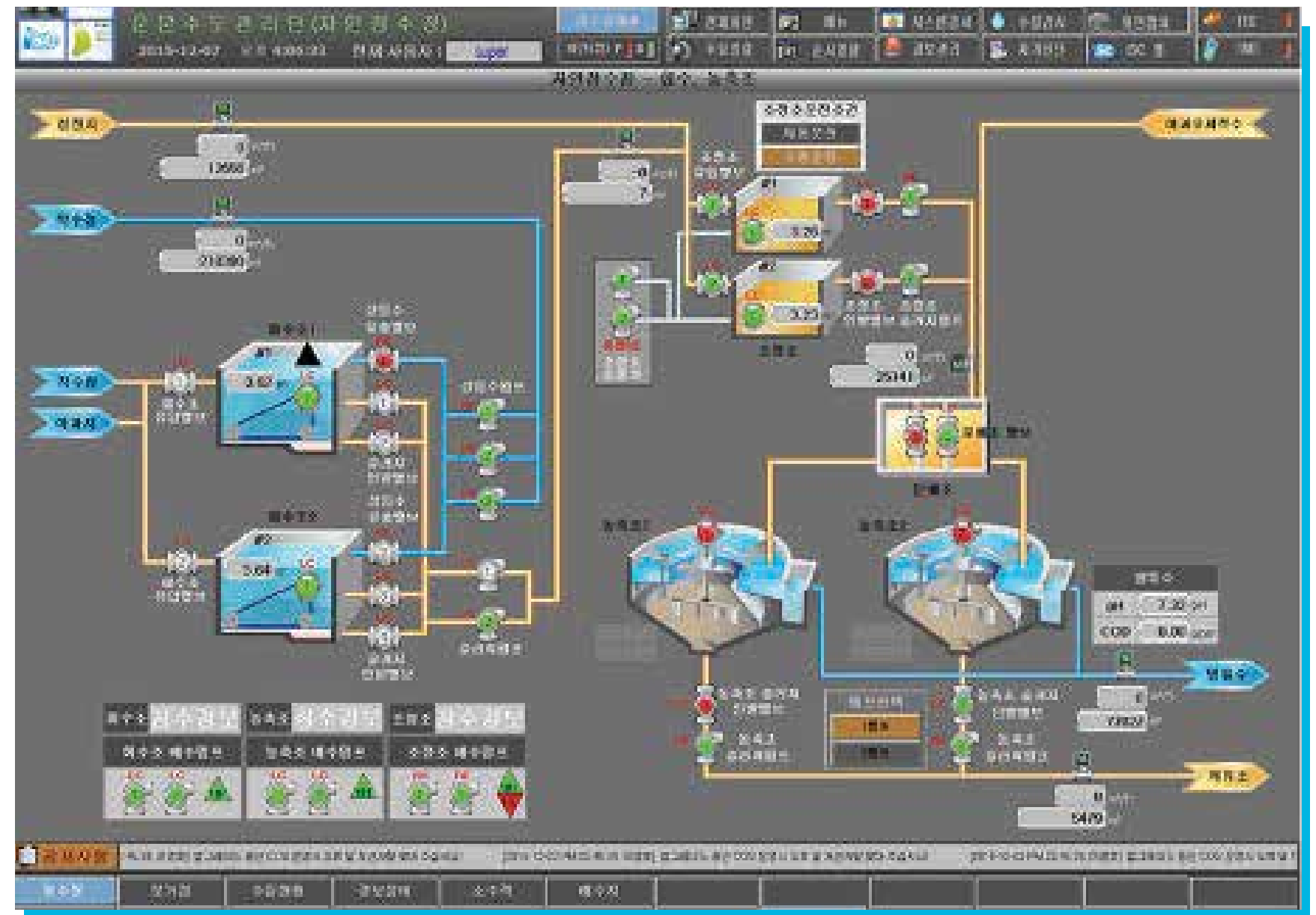

iFIX is ideal for use in Water/Wastewater facilities and is installed in some of the largest plants around the world. And, Proficy is a proof point of GE’s lean strategy by delivering a customer solution that simultaneously improves a customer’s operating and environmental performance.

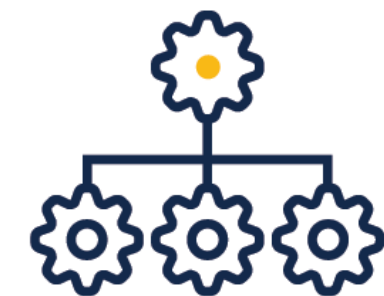

Water, Water Everywhere

The iWater system interfaces with water treatment equipment management systems, application computers that need to forecast the system, and real time water management DB servers. It has the flexibility to communicate with other third-party software even though local PLC and DCS systems are included.

GE provides customer-focused OEM contact to achieve great customer satisfaction and has stepped forward as a long-term business partner with a win-win strategy. K-water developed many efficient applications as well as mobile monitoring system and included in the iWater brand as part of its business master plan.

An integrated operating system, the iFIX-based GIOS has many redundant features and is functionally distributed for the highest level of reliability and performance. Identical servers run in parallel, so if one fails, the client can switch to the other server automatically. And, the file server contains recovered process values, messages, and data from the failure time period that can be automatically updated from the archives. In addition, the iFIX server controls the data processing of all events from RTUs and SCADA in the RDAC system. GE technology can also help K-water to secure new water resources by building more small and mid-sized environmentally friendly dams and by building a society free from worries about water stress with technologies for alternative water resources such as deep ocean water, groundwater and desalination.

“We provide a wireless tablet environment by using iFIX’s option of Proficy WebSpace and multi-sessions. It enables K-water’s operators to check data at sites when they fix some equipment failures, so that operators’ maintenance work is getting quicker and more efficient.” Hong Jintaek, System Integrator developer for K-water said.





SAIC-GM

Shanghai Automotive Industry Corporation (SAIC) and GM — Designed for success



SAIC-GM Taps GE and CIMPLICITY® to Drive Turnkey Automation Solution at New Plant

When the Chinese government named the automotive industry a pillar industry for development, it seemed only natural that the Shanghai Automotive Industry Corporation (SAIC), China's largest passenger automobile manufacturer, and General Motors (GM), the world's largest full-line vehicle manufacturer, would team up to form SAIC-GM.

SAIC-GM's production facility in the Pudong area of Shanghai is a \$1.5 billion, 5,920,200-square-foot (550,000-square-meter) plant that includes a press shop, body shop, paint shop, general assembly shop, and powertrain shop. Considered the largest and most innovative automobile complex in China, SAIC-GM primarily supplies China's businesses and government, producing Buick mid-size sedans, the Buick GL, wagons, and luxury compact sedans.

Before the first Buick rolled off the line, SAIC-GM selected the diversified services, technology and manufacturing company



— the General Electric Company — to unlock a \$65 million turnkey communication and control and power distribution system, as well as provide process equipment and support, that would actively support GM's production practices. With GE's automation team in the driver's seat, GE Electrical Distribution & Control was soon riding shotgun, together

designing a state-of-the-art communication and control and power distribution system to operate within GE's overall communication plan.

For its part, GE's automation and MES team developed a \$15 million communication and control system guided by its renowned CIMPLICITY, manufacturing enterprise-wide software and supported by Microsoft® Windows®, and Intel-based server and workstation computers. Four subsystems — the Process Monitoring & Control (PMC) system, the Target Control System (TCS), the Automatic Vehicle Identification (AVI) system, and the ANDON system — are connected by a GE provided network to monitor and control SAIC-GM's five shops. With thousands of machines and miles of conveyor systems, GE's turnkey automation solution effectively minimizes idle equipment and personnel, maximizes uptime and productivity, and operates seamlessly within the broader scope of the GE framework.

Results

- Maximum uptime and productivity
- Real-time data reporting
- Lower inventory and reduced material consumption
- Greater quality, less rework



Auto Assurance: SAIC-GM's Production Monitoring and Control System

Process Monitoring & Control (PMC) System

Working to maximize equipment uptime and process productivity, SAIC-GM's PMC system employs over 400 PLCs collecting data from 60,000 I/O points. CIMPLICITY HMI/SCADA software monitors production equipment conditions, generates and logs alarms, and communicates process status in rich graphic displays. The user-friendly but powerful CIMPLICITY software allows operators to generate nearly 4000 different reports and trending charts, including production counts, WIP totals, and process cycle times. Control functions are also provided by the system to allow authorized operators to start and stop production lines.

To support troubleshooting and repair efforts, CIMPLICITY quickly detects equipment and production problems, immediately notifies the appropriate maintenance team, production manager, or process support engineer, and provides diagnostic data for speedy repair efforts. Essential to a facility of this size, SAIC-GM's PMC system minimizes production downtime that can result from mechanical or production-related problems.

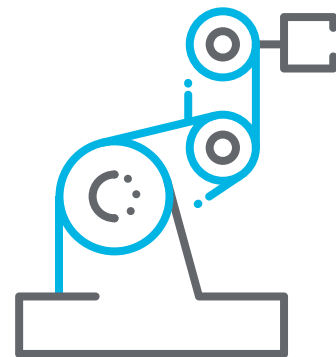

Target Control System (TCS)

SAIC-GM's TCS controls the movement of vehicle bodies into and out of the body distribution center using several modes of operation from fully automatic to fully manual. Like the PMC system, the TCS also employs CIMPLICITY software, but with the added feature of Tracker — a comprehensive CIMPLICITY option that provides tracking and routing control of the serialized vehicle bodies as they move through the production process.

With Tracker, SAIC-GM can dynamically collect and store a variety of vehicle body data, including process parameters, time stamps, and quality measurements. Operators can easily determine the location of a tracked vehicle body, display its data, and provide control commands to production equipment to process and route the body. Communication to

Automatic Vehicle Identification system and Conveyor controls is supported over the plant Ethernet network.

In addition to tracking vehicle bodies, CIMPLICITY determines where to store vehicle bodies arriving from the body shop, sequences vehicle bodies into the paint shop, decides where to store vehicle bodies returning from the paint shop, and again sequences vehicle bodies into general assembly. The TCS and similar routing control systems are used extensively in automotive facilities to efficiently and effectively control vehicle flow based on parameters such as production schedule, optimum color blocking, consistent load balancing, and material availability. For SAIC-GM, the TCS effectively optimizes production flow and productivity and, due to its efficiency, minimizes paint costs and reduces paint emissions.

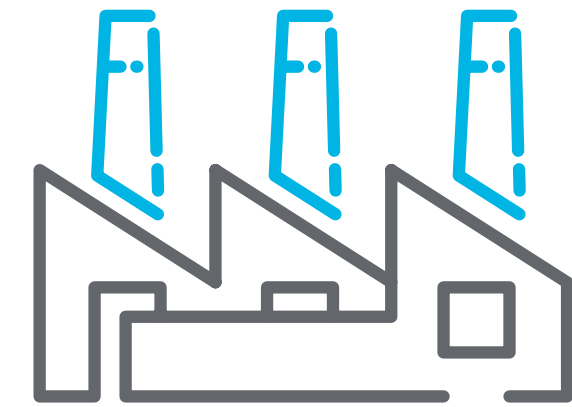

Automatic Vehicle Identification (AVI) System

The plant's Automatic Vehicle Identification (AVI) System identifies and tracks vehicles in the body shop, paint shop, and general assembly shop. Vehicles are identified by writing vehicle identification and configuration data to radio frequency (RF) tags mounted on each vehicle carrier. Vehicles are tracked by reading the vehicle data from the RF tags as they move through the production process.

There are two independent AVI systems; one is for the body shop and body distribution center (BDC), and the other is for the paint shop. The body shop/BDC system consists of one PLC networked with eight tag read/write stations located in the body shop, body distribution center and paint shop exit. Two of the stations in the body shop have automatic bar code scanners that read data from a label affixed to the body so that it can be uniquely identified by the AVI system when it enters the production stream. The paint shop AVI system also uses a PLC with 14 tag read/write stations. Each system controller interfaces with its own CIMPLICITY HMI-based operator station mounted adjacent to the associated system controller. The stations are available for system monitoring, maintenance, and supervisory control functions.

Each AVI system also communicates directly with the TCS and SGM's FLEX system via the network, reporting vehicle locations and vehicle data to both. The AVI system also receives data from the FLEX system for storage on the RF tags. This data is read from the tags by other systems and is used for controlling the production process.

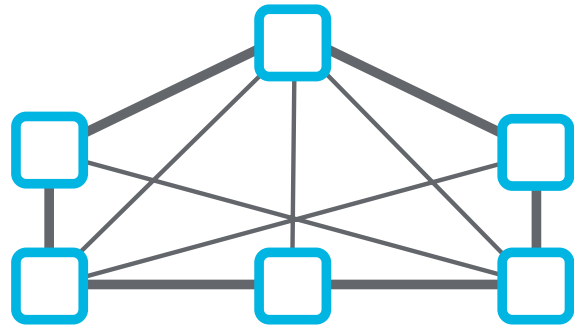

ANDON System

The Quality and Material ANDON System consists of two similar but separate subsystems. The Quality ANDON subsystem enables factory personnel to request help when a product or process quality problem is identified. Help is requested by pulling cords located along the production line. The action of pulling a cord sends a signal back to the operator interface, illuminating a section of a large display called an ANDON board that indicates where the problem exists along the production line. The Quality ANDON subsystem supports the synchronous manufacturing principles of producing quality products utilizing in-station repair rather than final process repair.

The Material ANDON subsystem allows each production area to automatically or manually request material before inventory is completely consumed. Factory personnel manually request more material by pressing a button. Material can also be requested automatically by sensors that detect a minimum inventory level. The manual or automatic request sends a signal back to the Material ANDON System, which displays the request in the material storage area. Fork truck drivers then deliver the requested material to the location, again supporting the synchronous manufacturing principles of just-in-time delivery.

Both the Quality and Material ANDON systems feature built-in tracking and reporting capability that compiles the number of ANDON calls, the number of line stops, and the resulting downtime. Problems are detected and resolved quickly and inventory is minimized. As with the PMC and TCS, the ANDON system avoids the high cost of idle equipment and people due to production problems and drastically reduces the opportunity for poor quality and rework.

Driving It Home

Fitting nicely into the framework of GE's master communication and control plan, GE's automation and MES team successfully integrated a comprehensive production monitoring and control system that will allow SAIC-GM to continue breaking new ground in auto manufacturing.

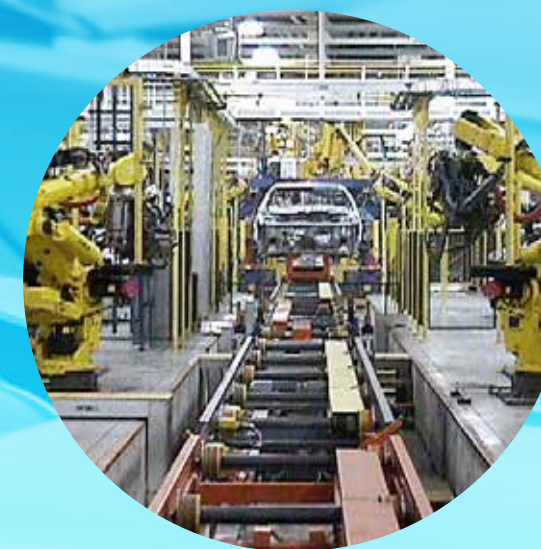

A Look Inside Shanghai GM

Press Shop

The 139,931-square-foot (13,000-square-meter) press shop features two 180-inch press lines with automatic pick-and-place panel transfer systems. Each line has five fully automated presses. Shanghai GM stamps 26 external metal parts at a rate of 500 parts per hour.

Body Shop

In the 265,868-square-foot (24,700-square-meter) body shop, heavy parts are lifted and moved by manipulators while 44 robots perform quality-sensitive tasks such as welding and sealing. The shop has agile tooling and a programmable design in the framing station that allows it to produce bodies for two completely different vehicles. An Electrified Monorail System (EMS) in the underbody sub-assembly and body side sub-assembly areas maximizes the flexibility of model mixing in the production schedule.

Paint Shop

The 548,958-square-foot (51,000-square-meter) paint shop is a state-of-the-art, environmentally friendly facility. Here, for the first time in China, provisions were made for the future use of waterborne primer and paint, which will effectively reduce exhaust emissions. Also for the first time in China, color-specific primer, which improves paint quality, is applied to all vehicles.

General Assembly Shop

The 452,084-square-foot (42,000-square-meter) general assembly shop features a unique T-shape layout pioneered by General Motors. A prerequisite for just-in-time production, the building shape offers three distinct advantages: docking stations permitting line-side direct delivery of parts; a centralized nerve center; and options for future expansion without interrupting production. Three automated conveyor systems complete the efficient assembly process.



Powertrain Shop

The 409,028-square-foot (38,000-square-meter) powertrain shop manufactures five major engine components for 4 and 6-cylinder engines that are used on its engine assembly line. This state-of-the-art engine assembly line can produce the mix of 4 and 6-cylinder engines required for the vehicles SGM-GM produces, as well as for other vehicle manufacturers in China. It also produces 5 major components for, and assembles, the first automatic transmission used on a production car built in China.

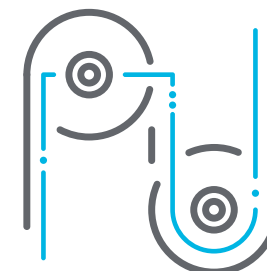



Digital Transformation at Copersucar

360° view of a Port Logistics Operation

Copersucar is redesigning their processes, reformulating their operation and facilitating decision-making, to place the company in the map of Industry 4.0.



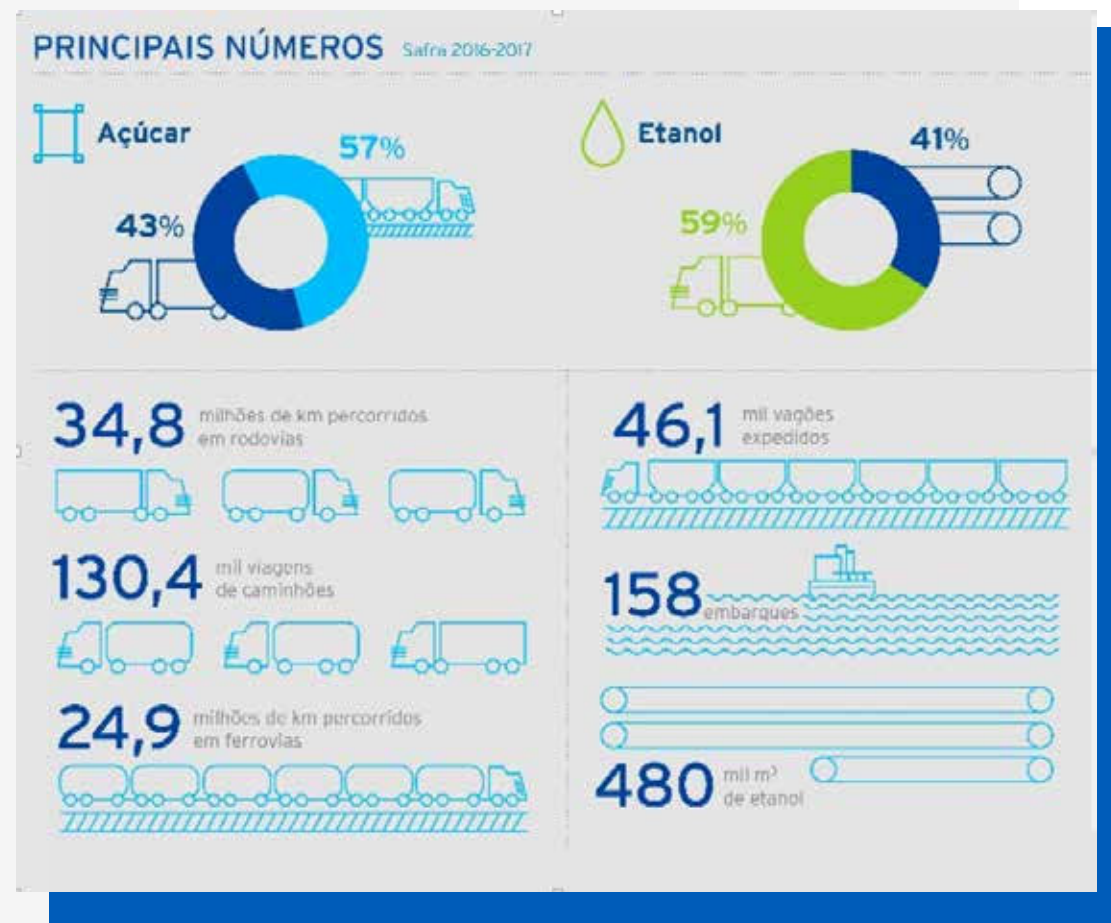

Source:

<https://www.copersucar.com.br/release/lucro-da-copersucar-atinge-r-254-milhoes-no-ano-safra-20162017/>

Working within the sugar cane supply chain and uniting field and industry, Copersucar is the largest Brazilian exporter of sugar and ethanol with integrated logistics throughout the business value chain.

With a unique business model in this sector, Copersucar doesn't count with production assets, but with sugar and ethanol acquisition contracts, supplied mainly by the member plants.

From the joint venture with Cargill, Alvean was created, which has accelerated the global expansion of the company.

Copersucar's strategy for sugar is based on the investment in multimodal terminals for the storage and transport of sugar, like in Ribeirão Preto and São José do Rio Preto, and at the Sugar cane Terminal Copersucar, located at Porto de Santos (SP), with a capacity of movement of 10 million tons of product per year.

Crop of 5.3 million tons of sugar and 4.2 billion liters of ethanol are commercialized with a \$254 million of consolidated liquid profit, at the end of the crop year. Copersucar owns the largest capacity of sugar and ethanol storage in Brazil.

For the products to reach their customers in tens of countries, it is necessary to have a complex logistics infrastructure, integrated by their own and contracted transshipment terminals and storage, in addition to an extensive outsourced road, rain and sea transport network.

Challenge

When a major fire struck the warehouses of the company, Copersucar had the need to update the entire operation.

In the area of Industrial Automation, an audit was conducted to identify the improvement opportunities through upgrades, new technologies and new processes. The Santos terminal was operating with some level of industrial automation, but the possibility to reduce contingencies and making operation and maintenance more predictable was identified. Additionally, it was not possible to quantify the losses related to performance and efficiency problems in a detailed manner and with identification of causes.

It was in this period that Copersucar brought in Marcelo Latrova to assume the Maintenance and Engineering Management, with a mission to redesign the processes and place Copersucar in the Industry 4.0 map, through the adoption of systems with an elevated level of integration, a consensus among the different approaches that exist today for digital transformation. Soon after, he had the arrival of the Industrial Automation Specialist Eduardo Pateis to supervise and implement the new project.

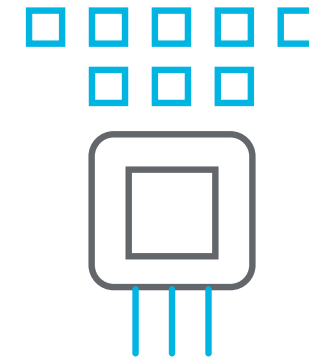

One of the priorities was to identify and address aspects of the process that could compromise the safety of the operation and impact daily production, due to possible unplanned downtime and complications.

With the new Industrial Automation project underway, Copersucar operates its regular activities at the same time as it manages the necessary changes, aiming at its modernization and increased efficiency as goals. This transition process is the most challenging point for the entire team of managers and operators.

Aiming for greater effectiveness, the team made the decision to restart and redesign processes and bring new technological solutions to overcome the challenges presented. It took nearly seven months within the Operational Control Center (CCO) to configure the systems.

The Engineering and Maintenance team is fully aligned with the corporate initiative, with the conviction that the project will increase Copersucar's competitive advantage. The current scenario is changing dramatically, however, with significant improvements at each stage.



Solution

Aquarius Software was the chosen partner for this project, acting as supplier of the systems and assisting Copersucar in the solution design, software training and support for the implementation of each system.

The overall idea of the solution includes the technological upgrade of the supervisory system with revision of the architecture used, upgrade of GE Digital's iFIX HMI/SCADA system, configuration of Hot / Stand-by redundancy, server virtualization and flexible access to client interfaces, operation via Terminal Services, with access management via ACP ThinManager. Proficy WebSpace allows viewing of the HMI/SCADA screens anywhere, any time through a web browser.

In addition, increased operational safety, change management and automated backup in automation applications (PLC and SCADA programs) will be delivered by AuVersy's VersionDog software.



Finally, through the implementation of the PIMS and MES suite, also from GE Digital, it will be possible to have the entire shipment process digitized, through the ERP (SAP) connection to obtain the information on what is stored and what to ship in each ship, following the execution of the loading and returning consolidated information on each operation.

“This project once again proved that it is possible to employ new software and services on existing technological bases, resulting in extraordinary results such as increased operational safety and greater integration between automation and corporate systems, with continuity of operation and investment greatly reduced.”

— Diogo Gomes, Aquarius Software



Critical Points

Within the scope of automation, PLCs were already interconnected in a control network, but there was no digital storage of process history. The records were made on paper. It was necessary to adapt the PLCs' ladder to the norms and to create new supervision system screens, processes that are in final phase of implementation.

The VersionDog deployment - has brought improvements in the dynamic of changes and access control of these programs. "Now it is possible to follow the changes / revisions in ladder diagrams, to know who performed them, when they were performed and, through the analysis of the data, to correct all the flaws and deviations," explains Pateis.

The solution will be completed with the implementation of the PIMS and MES systems, consisting of GE Digital's Proficy Historian, Proficy Plant Applications and Proficy Workflow software, which will allow the reading and analysis of the history and efficiency of the process, as well as integration with other Copersucar systems.

The PIMS and MES systems will also be instrumental in bringing relevant information to operational decision making. Latrova points out that from the implementation of these systems it will be possible to detect with more clarity and objectivity the causes of various types of outages and improve the process in general, including those related to the definition of specific training for operators.

“Protect processes. This is one of the essential roles of Automation.”

—Marcelo Latrova

Maintenance and Engineering Management, Copersucar



Project Highlights

- Implementation of a modern CCO, with digitalized and centralized process information, available in real time through intelligent and reliable systems, allowing the decision making with greater speed and assertiveness;
- Implementation of MES / MOM project (GE Digital's Proficy Plant Applications and Proficy Workflow software), enabling the control of ship loading efficiency and integration of process data with the ERP (SAP) system;
- Installation of change management system in automation and automatic backup systems (Auvesy VersionDog software);
- Virtualization of Automation Technology systems in IT (Information Technology) servers to increase the availability and robustness of the applications;
- Improved security and reliability of the system, with the implementation of a physical network backbone with intelligent redundancy and ring topology;
- Investment in the Lean Manufacturing methodology to make the whole operation more efficient, making the correct integration of Industrial Automation with each person involved in the operation of the terminal.

This new control philosophy also brought the need to create an Operational Manual that is in the process of being elaborated and a final training for the operators.



Figure 1. Operational Control Center of the Copersucar Sugar Terminal (TAC)

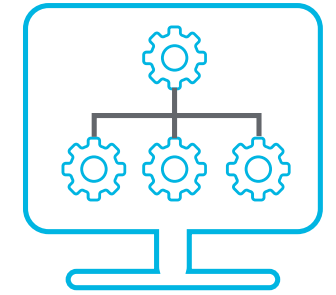

Technology employed	Main function
iFIX HMI/SCADA	Supervision and Control (SCADA)
Proficy Webspace	Viewing iFIX through a Web browser, anywhere, any time
Proficy Historian	Process Historian (PIMS)
Proficy Workflow	System Integration (Including SAP), eSOP and process automation
Proficy Plant Applications	Efficiency management of the operation (MES/MOM)
VersionDog	Automatic change management, SCADA backup and PLC programs
Thin Manager	Remote access management via remote desktop (thin clients)

Results

At the current stage, some major results have been obtained:

- With the advances in the implementation, it is notable that the number of overtime necessary has been reduced drastically, which is reflected in a higher quality of life for all those involved in the operation and in economics for the company;
- Several reports that help make decisions are now available. These reports are critical for process adjustments, as well as assist in the planning of activities, resulting in higher productivity;
- An automatic collection of historical data and the integration of the systems made the teams use their time in a more efficient way, since, with the direct and assertive visualization of the processes, the terminal operators could focus on the guarantee of operational efficiency, instead of spending their time collecting and analyzing manual data as previously required;
- Operators now work in much more organized and logical physical and operational environment. This also increases productivity and quality of life at work, in addition to increasing operational safety.

“If you solve your problems faster and more definitively, you gain operational agility. This is critical for our business.”

— *Marcelo Latrova*

Maintenance and Engineering Management, Copersucar

Next Steps

One of the next steps is the standardization of the operating interface. There will be similarity of processes and screens of the Supervisory System. This means that the operator working in one position may work in another, or in different shifts, with parity of procedures.

Another clear perspective is the continuous integration and collaboration between the Industrial Automation and IT teams. At Copersucar there is a reconciliation of the goals of continuous improvement of the two teams. This creates an extremely positive scenario for the company to follow its Digital Transformation journey and obtain solid results, in line with Industry 4.0's propositions.

Partnership with Aquarius Software

Copersucar had been a long-time user of the SCADA system distributed by Aquarius, GE Digital's iFIX, and planned the version upgrade when it entered the search process for partners for its new Industrial Automation projects. Analyzing the Aquarius portfolio, he was surprised to realize that he could solve all his challenges through a single partner, in an objective and integrated way.

Aquarius offered support beyond expectations, including expert advice for project management. One of the highlights was support in integration with IT, a subject dominated by the Aquarius team, with experience in other projects.

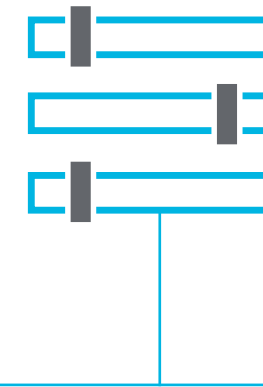

“ My practical view of Industry 4.0 is to reduce costs and search for operational efficiency through IIoT and the use of advanced technologies. I also see the autonomous systems, tracing routes and performing autocorrections.”



“ The experience and dedication of Aquarius' team of professionals generated a relationship of trust between companies. Our teams worked together throughout the project.”

— Eduardo Pateis

Industrial Automation Specialist, Copersucar



Rübig Improves Steel Treatment with Real-Time and Remote Visualization from CIMPPLICITY HMI/SCADA



Overview

Steel is tough—and yet so sensitive in its alloy and surface structure—especially when it comes to spectacular applications in the most adverse environments, such as in the automotive, aerospace and wind energy industries or in tool making.

RÜBIG DRIVING SUCCESS

For such tough requirements, the Rübiger GmbH & Co. KG company has developed the plasma nitriding process over many years of research and development work, which makes the surface structure of steel particularly resistant. As powerful as the plasma nitriding system from Rübiger is, its CIMPLICITY HMI/SCADA system from GE Digital, implemented by partner Taschek & Gruber (T&G), is just as powerful – providing many benefits as Rübiger grows and exceeds the needs of all customer requests.

Hardening steel surfaces

In order to be able to harden steel surfaces, a wide variety of nitriding processes are usually used, such as salt bath or gas nitriding. However, if you want to achieve increased resistance to abrasive, adhesive and corrosive wear, only one nitriding process is possible, namely that of plasma nitriding, which has only been used for about 20 years.

In this process, nitrogen is selectively mixed into the edge zone of iron-based alloys in an ionized gas atmosphere. This sounds easier than it is and requires a high level of know-how in materials and process engineering. It is therefore not surprising that so far only three providers worldwide have shared the market for plasma nitriding. One of these companies is Rübiger GmbH & Co. KG from Wels in Upper Austria.

Plasma nitriding - a specialty in material treatment

“Our strength is the individual development of plasma nitriding processes in order to meet customer requirements in terms of nitriding hardness, connection layer thickness, corrosion protection and oxide layer thickness - for individual parts up to large series,” explains DI Andreas Gebeshuber, the application engineer responsible for the R&D area and sales manager at Rübiger. “All kinds of alloys on steel or cast iron can be treated. The range of nitriding processes used ranges from the application of a certain ceramic connection layer on the surface of the workpiece to a diffusion zone for good flexural fatigue strength.”

At Rübiger, the Rübiger SIR program stands for the development of systems and processes for optimal performance enhancement of the surface of tools and components made of steel materials in the spirit of environmental protection. SIR enables a reduction in hard fine machining and offers manufacturing integration, partial nitriding and process combinations. In addition, the lowest emissions result with minimal gas consumption. The elimination of hard fine machining enables savings of around 20%. The MICROPULS® Everest system enables optimal use of the RÜBIG SIR range.

Environmentally conscious as well as energy efficient

The MICROPULS® Everest plasma nitriding systems from Rübiger offer the highest level in nitriding technology for contract heat treatment for the automotive, aviation and wind energy industries. Constant further developments make the Rübiger plasma nitriding systems the optimal solution for premium applications. The MICROPULS® Everest provides the profitable redesign in terms of heat treatment because its technological uniqueness optimizes the processes of its users by means of high-tech plasma generators and thus contributes to an increased degree of filling as well as improved economy. This is also ensured by an optimal, environmentally friendly energy concept: independent multi-heating and cooling zones, temperature measurements that are carried out directly on the component, as well as the avoidance of toxic gases, are responsible for economical and environmentally friendly energy consumption and, at the same time, perfect reproducibility.



Customized fit

In addition to these advantages, users of MICROPULS® Everest achieve increased strengths and tailor-made surfaces in the production of their components, which can be flexibly adapted to their layer requirements depending on the component requirements – regardless of the component geometry. And if further processing of the components for tribological or corrosion-like protective measures is possibly required, Rübiger also makes this possible with its PLASOX® process range.

Flexible through automation

The flexible system concept of MICROPULS® Everest is perfectly suited for in-house sourcing including any future upgrades. This is also due to their individually developed automation concept, which enables the system to be integrated into any manufacturing environment and meets the requirements of a visionary factory of the future, like Industry 4.0. For example, the user-friendly operation via remote access and online diagnostics are already the system standard – which provides considerable efficiency to be gained in the process flow.

For example, the CIMPLICITY HMI/SCADA system from GE Digital and partner T&G has been in use at Rübigen for the visualization of the processes and for communication of the control with MICROPULS® system very successfully for years.

Siegfried Zauner, software developer for MICROPULS® at Rübigen, explains: “At the time, CIMPLICITY was one of the few HMI SCADA systems that could communicate in all facets with the Eurotherm control system we were using at the time.”

Martin Toth, project manager at T&G, explains the reason for this: “CIMPLICITY has always had an open interface design and has been able to integrate numerous third-party systems and devices. With the help of native drivers and standard communication interfaces such as OPC, data can be recorded from virtually any third-party device.”

Martin Toth,
Project Manager at T&G



Higher performance standards

“In the meantime, however, we recently evaluated all of our processes again and during this, of course, we also looked at all of CIMPLICITY's competitors and examined any high-level programming languages. In the end, we came to the decision that there would be no benefit from switching to another HMI/SCADA system and that we would therefore continue to use CIMPLICITY. In addition, from the beginning we were and are more than satisfied with the support in the visualization area by Taschek & Gruber (T&G),” said Siegfried Zauner, confirming the continuity of the cooperation.

CIMPLICITY gives the plant developers at Rübigen as well as the operators the opportunity and the secure-by-design technology to visualize every aspect of the manufacturing environment, equipment and resources, to monitor them automatically and to deliver reliable production data to higher-level analysis applications.

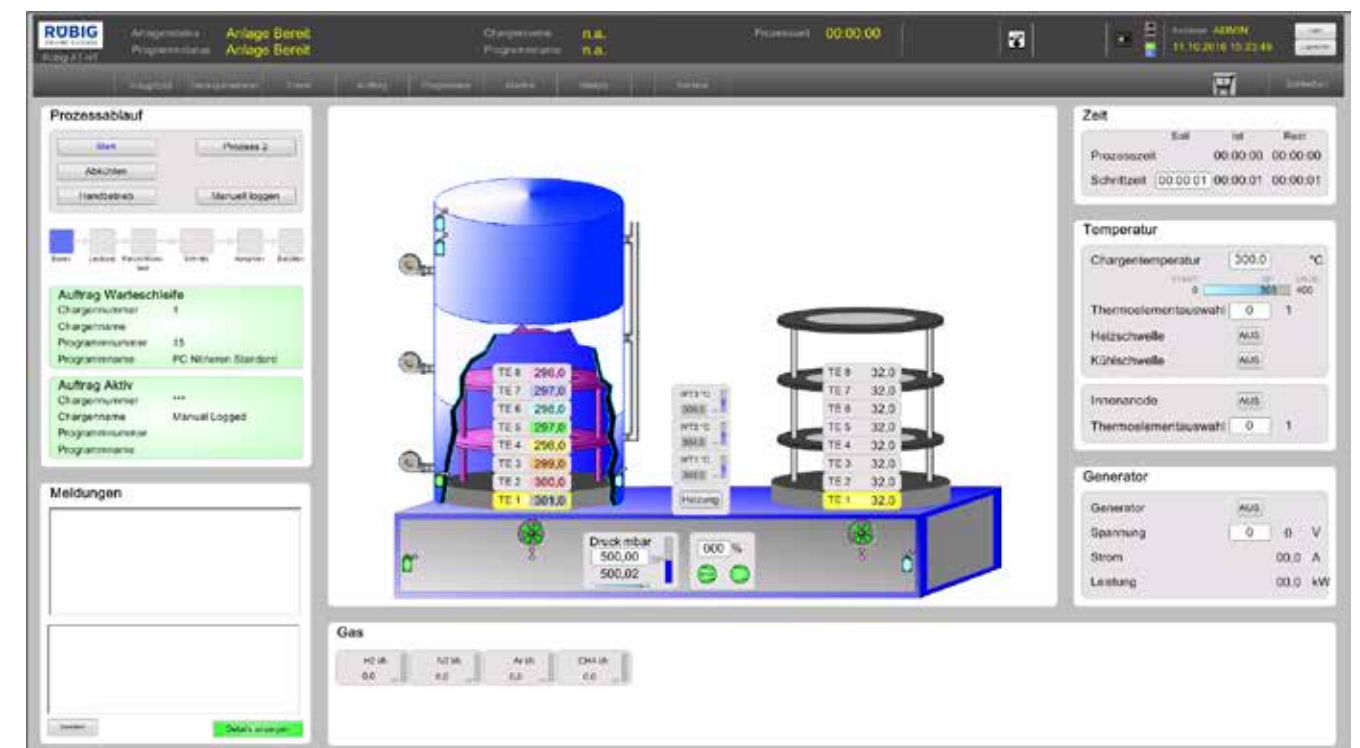
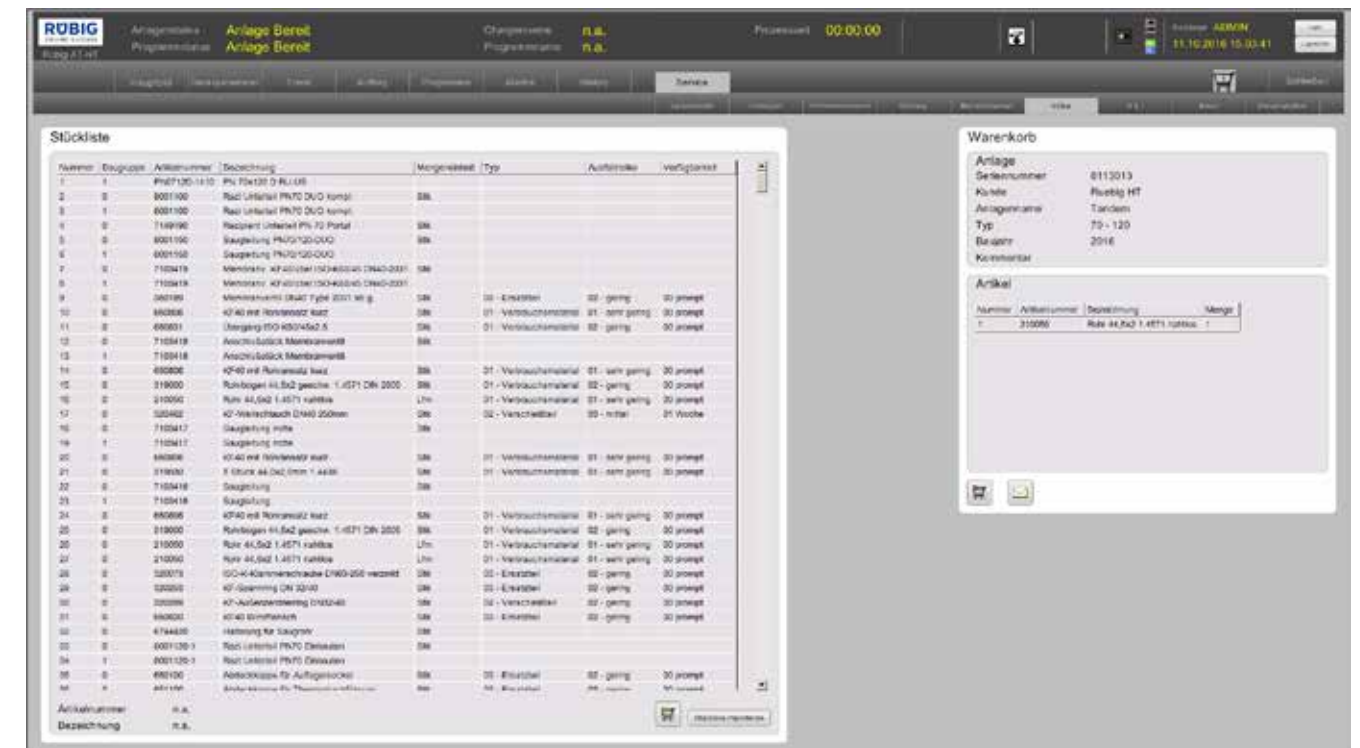

Features for all configuration requirements

"What I particularly like personally is for example, in the document library. I can create programs and can easily integrate them into the visualization of the system. The system operator can be provided with information of any kind without having to go into programming. This is a feature that hardly any other program offers," said Siegfried Zauner, describing one of the programming benefits from CIMPLICITY.

This means that applications can be called up in the background which are written in a wide variety of programming languages.

"These are standard functions in CIMPLICITY. If, as with Rübigen, you now have special system logic where you program certain functions in a high-level language, you can develop this configuration and embed it in the entire visualization in addition to the existing visualization images," explains Martin Toth.

In this way, Siegfried Zauner has already programmed many visualization functions for the MICROPULS®, for example an operating hours counter, record displays for process costs per batch, recipe, system and work orders or a shopping cart for defective components to be replaced with all vacant additional information, such as technical information about the component itself, e-mail ordering options to the in-house purchasing department or directly to Rübigen - and more like that.

"Another special feature is that I can also create my own design elements in the programming, for example to be able to display the status of a certain value. Here in CIMPLICITY there is a broad 'playground' of ready-made templates that I can design accordingly for individual process scenarios. I can even develop user access authorizations for all system states in CIMPLICITY," said Siegfried Zauner, explaining further programming options.

For the software development team at Rübigen, it is therefore an easy undertaking for the standard systems to be configured to meet individual customer requests in the system visualization.

Easy-to-use operator displays in real time

Thanks to the real-time display with data that is recorded via SQL server, plant operators and the management team can make informed decisions at any time. As already mentioned, the user-friendly operation via remote access and online diagnosis also contributes to this.

For example, CIMPLICITY has a powerful Digital Graphical Replay (DGR) recorder, with the help of which events in time can be called up in slow motion, in real time or at a maximum of ten times the speed and analyzed graphically. In this way, problems can be identified and corrected, and their recurrence avoided. The DGR recorder even conveniently reproduces trend data and analyzes for the user.

With the Action Calendar, the calendar-based time planning of manufacturing events and associated actions can be created, maintained and executed in order to control one plant or several plants according to a predefined schedule and according to the predefined recipes. The system status is - as already described for the features to be programmed - continuously visualizes for the operator: operating hours counter, recordings for the process costs per batch, maintenance indicators

for defective components to be replaced with all vacant additional information, a shopping cart for ordering spare parts - and much more.

Exceptional competence

"The big plus of the Rübigen Group can be found in the high level of process engineering know-how through the in-house hardening shop and our many years of experience in the development of systems. This gives our customers the security of being able to treat the surfaces of their workpieces with the latest state of the art in premium quality," sums up Andreas Gebetshuber and Siegfried Zauner, adding: "The CIMPLICITY HMI/SCADA system provides us with powerful support for the visualization of processes and for communication with the system control. And, Mr. Toth from T&G always gives us support if necessary!"

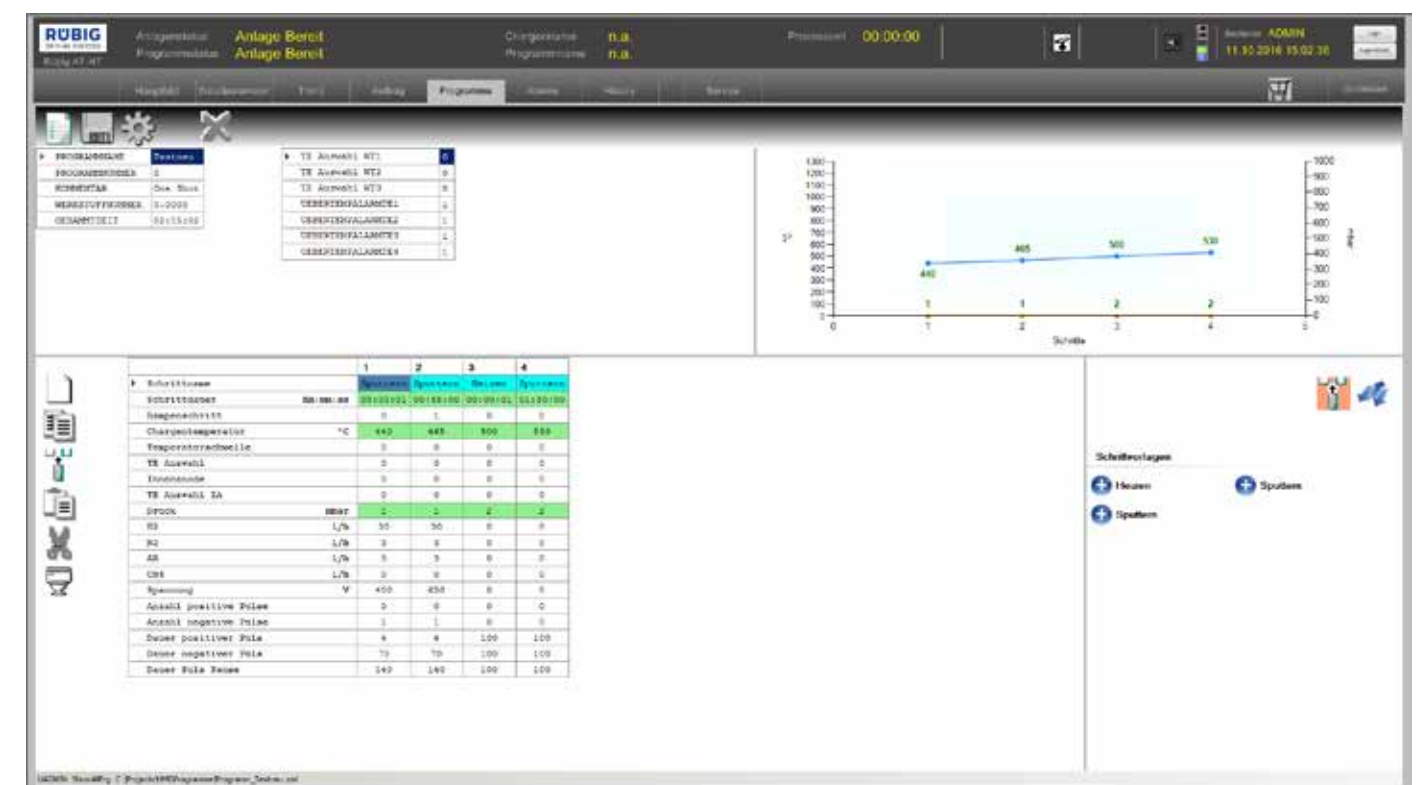



IMA Active chooses iFIX HMI/SCADA and Proficy Historian to meet data integrity requirements in regulated industries



Results



▶ **100%**
Data integrity



▶ **28**
Machine families in just one division



▶ **Compliance**
Machines for regulated industries



▶ **Easy customization**
Specific global customer requirements

About IMA Active

Pharmaceutical products, cosmetics, food, tea, coffee: the IMA Group has been designing and manufacturing automatic machines for the processing and packaging of all these products for 60 years—since 1961 to be precise—and today it is the undisputed leader in this field.

The company, whose name derives from the acronym of Industria Macchine Automatiche, is based in the heart of the Packaging Valley, the cluster of advanced mechanics and industrial automation in Emilia Romagna.

Since the 1960s, IMA has achieved continuous growth thanks to its operations but also and above all to constant research and development of innovative technological solutions that the market appreciates.



Delivering maximum reliability, quality and compliance

iFIX HMI/SCADA and Proficy Historian, both developed by GE Digital and supported in Italy by [ServiTecno](#), allow IMA Active to have a standard engine for the machine interface and industrial data management across its entire portfolio of machines for regulated industries.

Flexibility and reliability as values

For a company that combines organic growth and acquisitions (recently, the Emilian Group acquired 82.5% of Tissue Machinery Company, 70% of Ciemme, 60% of Perfect Pack, and majority of Atop, world leader in the automation sector for the production of electric motors for E-traction), it is essential to be able to make use of an ecosystem of partners who are able to support the company in its mission to add value to its customers.

In the sectors IMA addresses, there are many complexities and critical issues – very different from each other – and all must be given a solid and reliable solution, which delivers the highest quality and compliance of the final product.

For this reason, the partners must support IMA not only in technologies with proven effectiveness, but also high quality and, above all, reliable support in the long term.

Customers often turn to IMA in the Post-Sales phase even after tens of years from the original purchase, both for maintenance activities and for those "revamping" operations that allow these machines to remain in step with the continuous technological transformation and to reduce downtime and training time of less and less specialized operators. It is no coincidence that one of IMA's inspiring slogans is: "Different markets. One flexibility on a global scale."

The pharmaceutical sector and the experience of IMA

In the Life Sciences and Pharma sectors, the Emilian company currently operates with four brands: IMA Active, IMA Life, IMA Safe and IMA BFB.

IMA Active, in particular, designs, develops and manufactures machines for the production of solid oral forms, while IMA Life deals with liquid drugs and freeze-dried products.

In these areas, "the times that mark the activities are often not short: everything must be planned and then proceeds in the order of months and even years," Marco Minardi, Automation Manager of IMA Active, points out. "In our sector, for example, it takes more than a year between the order of the machine and the first product being ready for patients, mainly due to the regulations that frame the sector. Vision, strategies and actions are therefore necessarily medium and long. With a view to an expected life of 15 or 20 years for machines and systems, having and being able to count on solid partners is a very important value: in our case these evaluations have a significant impact."

In the past, the IMA Group used custom technology platforms for the various machines in the Pharma and Food sectors. Then in the pharmaceutical sector, the Emilian Group made some acquisitions, including those of BOC Edwards, with plants in the Netherlands and the United States, and of the Zanchetta of Lucca, both companies that used the iFIX platform as an HMI solution.



Subsequently, the idea was born in IMA Active to create a new HMI solution that could be used on all the machines in its broad portfolio, which would provide brand recognition and a high standard of usability and reliability of the operator interface.

Choosing iFIX HMI/SCADA as the brain between machines and users

It is in this context that the collaboration between the IMA Group, GE Digital and ServiTecno (an Alliance Partner that distributes and supports GE Digital software in Italy) comes to a decision: after an intense analysis of solutions on the market, IMA Active decided to focus on iFIX as a pillar to build the Kortex MAX HMI/SCADA platform.

"The interface is the way in which the machine communicates with the operator: it is therefore a strategic element in the overall design of a product. It always has been, but it is even more so today, with the advent of mechatronics and the increase in the engineering complexity of the machines. All these conditions have determined the need to find an adequate, flexible and efficient product, which led us to choose iFIX as the technological base on which to develop our platform that we have called Kortex MAX with reference to the concepts of 'cerebral cortex and maximum usability,' which are two essential characteristics of the system," Minardi explains.

In choosing GE Digital and ServiTecno, a fundamental activity was the evaluation of the characteristics of the product and the profile of the two partners. "In our choices," underlines Minardi, "we look for both up-to-date technology and the reliability of the supplier, its ability to support us. What ServiTecno does is a fundamental value for us: it helps us to solve the technical and technological problems that inevitably arise, present by following us in the various design and implementation activities. This is for us a value at least equal to the technological specifications. "

And so today, within the IMA Group, the two divisions IMA Active (specialized in machinery and solutions for the production of oral solids) and IMA Life (specialized in the sector of liquid drugs), having partly overlapping characteristics and needs, are both standardized on iFIX as the HMI/SCADA platform.

"Focusing activities on a single platform also allows us to manage resources at production peaks in a flexible way, dynamically allocating them to orders, precisely because of the choice of a common platform," explains Minardi.



"With the continuous growth of the IMA Group, the industrialization of processes has become very important. Just to give an example, in our division alone we manage 28 families of machines for process and product treatment, each of which has various sizes and a considerable degree of customization. When we choose the solutions to use for our automation, we always make a 360-degree, holistic assessment of the technology, the product and its resources: the specific technical potential is obviously the basis, but the related services are no less important including long-term support," Minardi says.

Meeting Regulatory and End Customer Requirements with Automation

There are several technical characteristics of iFIX that led IMA to choose it as the pillar of its operator interfaces.

The first essential point to be addressed, when adopting a technology in the pharmaceutical field, is the management of Data Integrity. Here, GE Digital has accumulated over thirty years of product development experience, which makes the difference.

"In the world of Life Sciences and Pharma, iFIX has always been a recognized and recognizable player, its reputation was therefore a tangible value."

– Marco Minardi, Automation Manager, IMA Active

In a regulated sector such as the pharmaceutical sector, the data is fundamental: "Without the data, the lot must be thrown away," effectively summarizes Minardi.

iFIX also integrates seamlessly with GE Digital's Proficy Historian, an industry-leading process data management solution .

"Proficy Historian plays a central role in the qualification of process data and to keep track of data integrity, which includes data traceability, for both regulatory and process engineering purposes to optimize parameters and improve the quality and repeatability of operations."

– Marco Minardi, Automation Manager, IMA Active

iFIX and Proficy Historian also allow seamless integration with relational databases and contextualize the information collected and stored over time, such as for the purposes of alarming production systems.

Another added value of iFIX is its modularity and adaptability in relation to the machine and line architectures, characteristics that determine how the machines are proposed to the customer in terms of integration with the plant floor and with the architecture of the management systems. iFIX natively supports all the main standards in use in the pharmaceutical sector, thus making it relatively easy for IMA to propose a solution that easily integrates into all scenarios.

For example, iFIX also supports the Terminal Server architecture. "With the increasingly strong integration between the OT and IT world, the use of the iFIX SCADA system in Client-Server architecture with multiclients is a value capability, for example for customers who have to install our machines between two different environments or to improve general ergonomics," explains Minardi.

Since, as noted, IMA Active produces a considerable variety of solutions, another added value of iFIX appreciated by Minardi is the ability to configure the HMI/SCADA system: "As for configuring the interface for a specific machine, iFIX allows us to reflect the configuration chosen by the customer, automatically generating an interface that includes all and only the features you need."



A look to the future

In the pharmaceutical world, teams are cautious about making changes, and the full evaluation of final results are fundamental before every innovation. The speed of adoption of the innovations must also deal with delivery times ranging from 8 to 24 months.

However, this does not mean that innovations are not considered, quite the contrary. "We have a specific agreement with ServiTecno: at each revision of iFIX, they provide us with a pre-analysis on the impact of the transition in our specific case; then there are test sessions, evaluation and verification of the various operational steps, and a verification of the real effectiveness of the systems updating and development."

The quality of data in the pharmaceutical sector

In a highly regulated production environment such as pharmaceutical, quality and data integrity are critical elements because they are closely related to human health.

Data Integrity can be defined, in relation to data management, as the guarantee that a set of data is correctly managed during the production process and in relation to all operational areas (production, laboratories and warehouses).

To be considered healthy, data must meet various criteria throughout its life cycle. The Food and Drug Administration (the agency in charge of controls on the food and pharmaceutical sectors) provides for the ALCOA criteria, an acronym that derives from the initials of the five qualities that the data must have: Attributable, Legible, Contemporaneous, Original and Accurate.

Although operating with longer timescales than non-regulated industrial sectors, "we can never allow errors of any kind, so, as mentioned, operational caution must always be maximum. The renewal and improvement of systems and solutions are in any case in order of the day, both as regards the 'hard' technological components, the machinery, the operational 'muscles' of production, and as regards the control and software part," Minardi says.

The team is looking at next steps in this successful collaboration that continues to innovate and always deliver maximum reliability, quality and compliance. This will be a "further strengthening of the path with GE Digital and ServiTecno," anticipates the Automation Manager of IMA Active, "for a collaboration that goes well beyond the final

In addition, ALCOA Plus (ALCOA+ or CCEA) criteria has also been defined, adding that the data must also be Complete, Consistent, Enduring, and Available.

It is clear that software technologies that natively support and manage these requirements in a standardized way, such as GE Digital's Proficy Historian, can be of great support in the system validation process.

Proficy Historian, for example, allows through its collector system to generate data records already associated with identifiers (e.g. product and lot) and time stamps and to send them, in a secure-by-design and encrypted manner, to the storage server. The data record, once generated, cannot be changed without codified procedures and is completely compatible with the reference legislation.

product, and necessarily brings together product and operational support in every phase and every evolution of the production systems."

Another possible area of development concerns frontier technologies such as Data Analytics and Artificial Intelligence. "In this field too, the IMA Group is moving with interest and attention: if there is an interesting software product, we will immediately take it into consideration," remarks Minardi. "These are technologies and solutions that must be highly customized, according to the specific needs to be met, and for this reason the availability of the technological and digital partner must be total. The goal is always very concrete: we must give the end customer a lot of added value, strong and tangible."

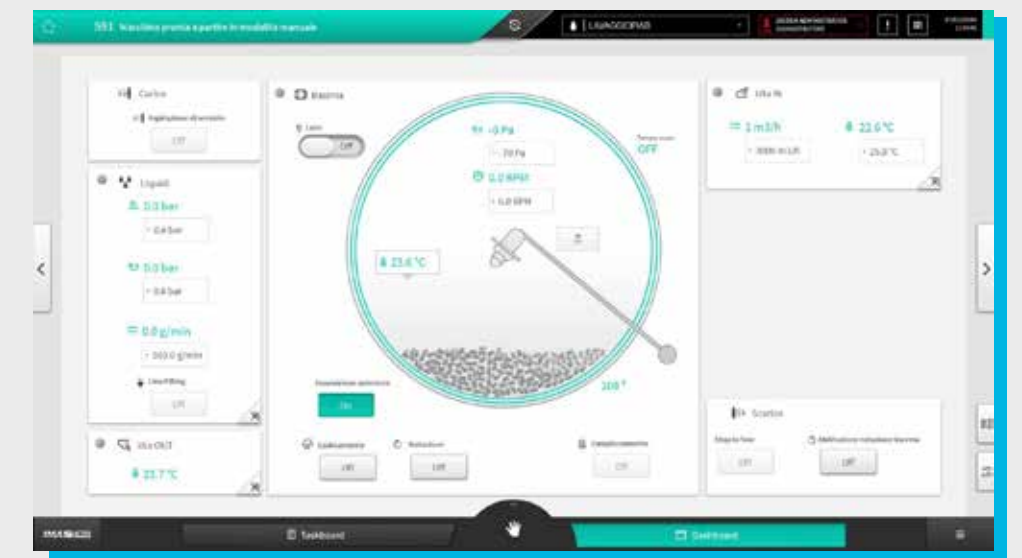



About Novotek

Novotek is the channel partner and local distributor for GE softwares in Northern Europe, UK & Ireland, Benelux and Switzerland. Contact your local Novotek for further information.

Contact Information

Novotek Finland www.novotek.fi

Novotek Group www.novotek.com

About GE

GE (NYSE: GE) is the world's Digital Industrial Company, transforming industry with software-defined machines and solutions that are connected, responsive and predictive. GE is organized around a global exchange of knowledge, the "GE Store," through which each business shares and accesses the same technology, markets, structure and intellect. Each invention further fuels innovation and application across our industrial sectors. With people, services, technology and scale, GE delivers better outcomes for customers by speaking the language of industry.

Contact Information

www.ge.com/digital

